

Centrifugal fans made of plastic



energy-efficient
corrosion-resistant
weather-proof



Index



Centrifugal fans made of plastic

Advantages, Design, Application	3
Specification direct drive	4
Specification belt drive	5
Type serie HF R ...-15 / 17 D DS1 Size: 125 bis 500	6
Accessories	48
Explosion protection ATEX	56
Housing positions	59



HF - Centrifugal fans
Type series HF R ...-15 / 17 D

Advantages

- Corrosion-resistant
- Energy-efficient
- Weather-proof
- Compact design
- Finely graduated sizes
- Fast availability of standard variants
- Inlet and outlet side with same diameters
- Wide range of accessories

Application

- Optimal for the extraction of corrosive gases from laboratory to galvanic exhaust air
- Handling of explosive atmospheres from Ex zones 2 and 1

Design

- Housing made of UV-resistant PEs
- Impeller made of PPs as standard
- Motor outside the airflow
- No metal parts in the air flow
- Use of different motors (Ex) possible

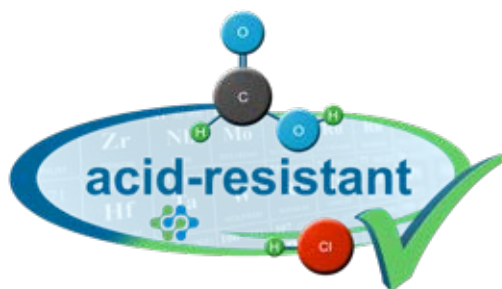

Repair switch
P. 54



Motor cover
P. 51



Sound enclosure
P. 53



Fans optionally available
for Ex-Zone!
P. 56

Specification

HF - Centrifugal fan with direct drive

in efficiency-optimized premium version „blue Hfan“

Corrosion resistant plastic centrifugal fan with PE-FR housing, RAL 7036, sintered, single inlet, inlet nozzle with seal as inspection opening, easy removal, condensate pipe at lowest point of the housing, splinter protection according to accident prevention rules as plastic coated wire mesh. Impeller with backward curved blades, statically and dynamically balanced, quality of balancing at least to G 6.3 (DIN ISO 21940-11), mounted with taper lock-bush on motor shaft. Fan frame in strong, welded steel construction, galvanized, with motor support plate. Fan frame suitable for mounting the housing with impeller and motor.

Manufacturer	: Hürner Luft- und Umwelttechnik	
Type	: HF R ... - .. D	
Housing-material	: PEs	
Impeller-material	: PPs	
Housing position	: ...	
Inlet diameter	: ...	mm
Medium	: exhaust air	
Volume flow	: ...	m ³ /h
Total pressure difference	: ...	Pa
Static pressure difference	: ...	Pa
Sound pressure level Lp2A(1 m)	: ...	dB(A)
SFP	: ...	W/(m ³ /s)
Motor power	: ...	kW
Voltage	: ...	V
Frequency	: ...	Hz
Rated current	: ...	A
Enclosure / motor protection	: IP 55 / PTC	

Accessories:

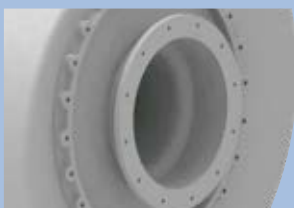

Flange connection
P. 49



Shaft seal
felt ring
P. 50



Shaft seal
Viton/Hastelloy
P. 50



Protection grid
P. 51

Specification

HF - Centrifugal fan with belt drive

Corrosion resistant plastic radial fan with PE-FR housing, RAL 7036, sintered, single inlet, inlet nozzle with seal as inspection opening, easy removal, condensate pipe at lowest point of the housing, splinter protection according to accident prevention rules as plastic coated wire mesh. Impeller with backward curved blades, statically and dynamically balanced, quality of balancing at least to G 6.3 (DIN ISO 21940-11), mounted with taper lock-bush on shaft of flanged double bearing. Fan frame in strong, welded steel construction, galvanized, with motor support plate and with belt guard. Fan frame suitable for mounting the housing with impeller, belt drive and motor.

Manufacturer	: Hürner Luft- und Umwelttechnik	
Type	: HF R ... - .. R	
Housing-material	: PEs	
Impeller-material	: PPs	
Housing position	: ...	
Inlet diameter	: ...	mm
Medium	: exhaust air	
Volume flow	: ...	m ³ /h
Total pressure difference	: ...	Pa
Static pressure difference	: ...	Pa
Schalldruckpegel Lp2A (1 m)	: ...	dB(A)
SFP	: ...	W/(m ³ /s)
Motor power	: ...	kW
Voltage	:	V
Frequency	:	Hz
Rated current	: ...	A
Enclosure / motor protection	: IP 55 / PTC	



Repair switch
P. 54



Motor cover
P. 51



Sound enclosure
P. 53



Fans optionally available
for Ex-Zone!
P. 56

HF - Centrifugal fan
Type series HF R ...-15 D

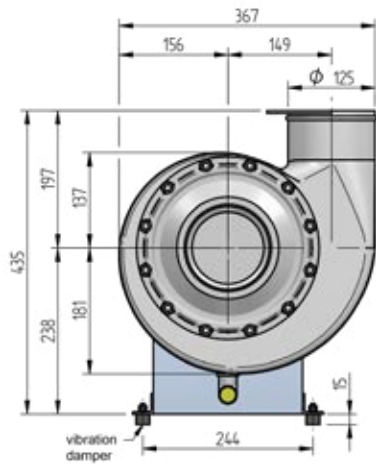

Direct drive

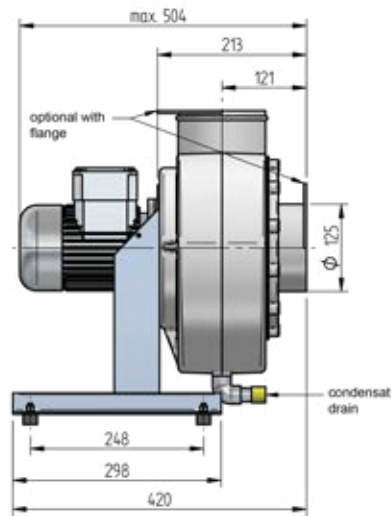

Accessories:

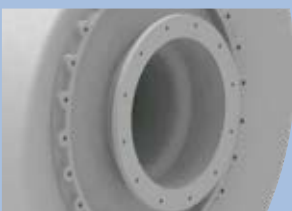

Flange connection
P. 49



Shaft seal
felt ring
P. 50



Shaft seal
Viton/Hastelloy
P. 50



Protection grid
P. 51

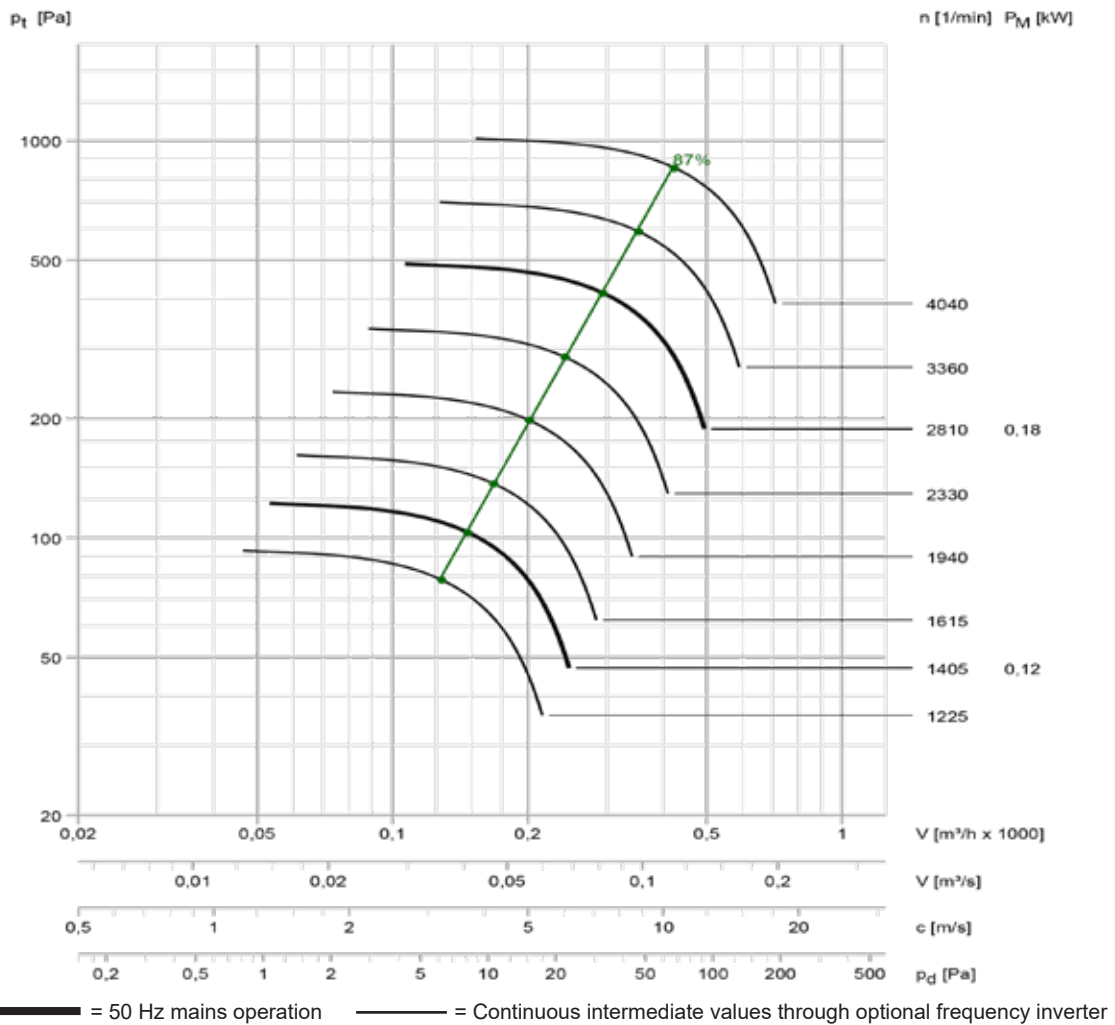

Acoustic level according to VDI 3731									
Speed [1/min]	Inlet level / outlet level of the duct sound level non-valuated; Lw3 = Lw4 [dB]								Lp2A (1 m) [dB(A)]
	63	125	250	500	1000	2000	4000	8000	
4040	81	81	80	78	72	67	59	50	63
3360	77	77	76	72	67	61	53	44	58
2810	74	73	72	67	62	55	47	38	53
2330	70	69	67	62	56	49	41	31	48
1940	66	64	62	57	51	44	35	24	43
1615	62	61	57	52	45	38	28	18	38
1405	59	58	53	48	41	33	24	13	34
1225	56	54	49	44	37	29	19	8	31



Repair switch
P. 54



Motor cover
P. 51



Sound enclosure
P. 53



Fans optionally available for Ex-Zone!
P. 56

HF - Centrifugal fan
 Type series HF R ...-17 D
 optional for ATEX zone 1
 in GR ...

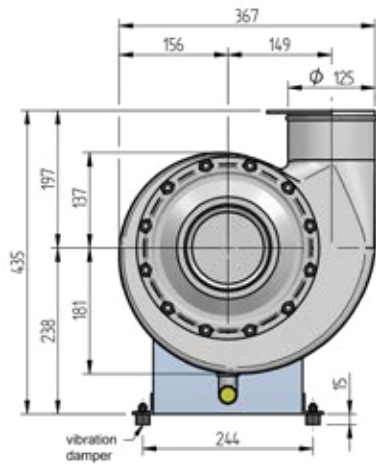

Direct drive

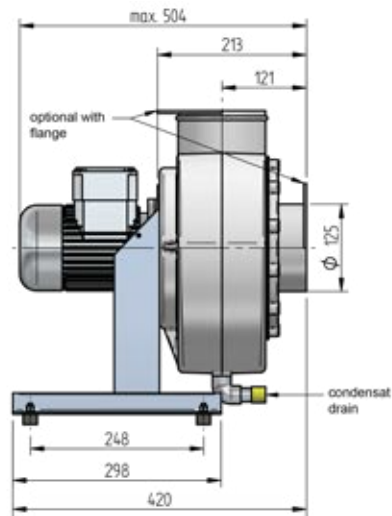

Accessories:

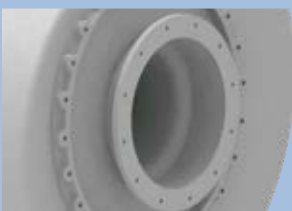

Flange connection
 P. 49



Shaft seal
 felt ring
 P. 50



Shaft seal
 Viton/Hastelloy
 P. 50



Protection grid
 P. 51

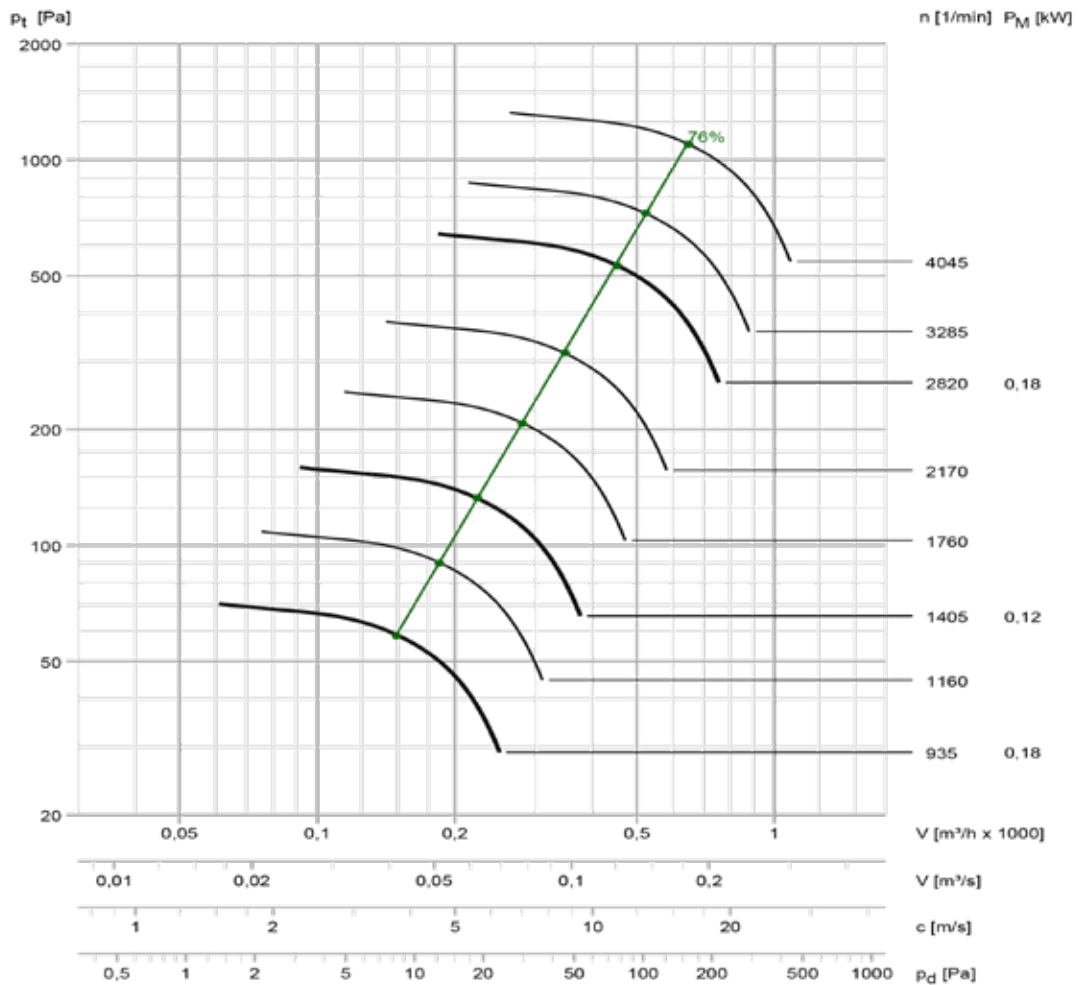

= 50 Hz mains operation
 = Continuous intermediate values through optional frequency inverter

Acoustic level according to VDI 3731									
Speed [1/min]	Inlet level / outlet level of the duct sound level non-valuated; Lw3 = Lw4 [dB]								Lp2A (1 m) [dB(A)]
	63	125	250	500	1000	2000	4000	8000	
4045	91	91	90	98	85	82	77	72	80
3285	85	85	94	82	79	75	70	64	72
2820	82	81	90	78	74	70	65	59	68
2170	76	75	84	71	67	63	58	51	61
1760	70	79	67	64	60	56	50	43	52
1405	65	74	61	58	54	49	43	36	46
1160	61	69	57	53	49	43	37	30	41
935	56	64	51	47	43	37	31	23	36



Repair switch
P. 54



Motor cover
P. 51



Sound enclosure
P. 53



Fans optionally available for Ex-Zone!
P. 56

HF - Centrifugal fan
Type series HF R ...-15 D

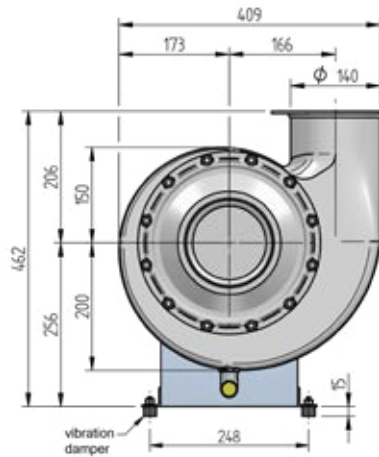

Direct drive

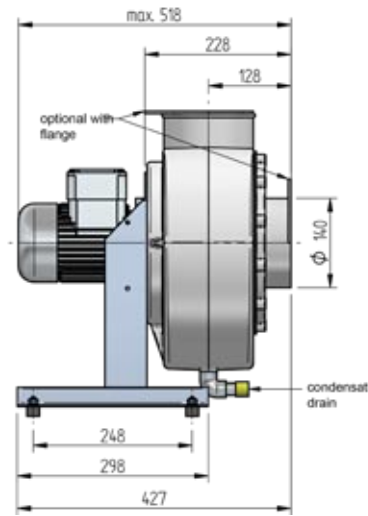

Accessories:

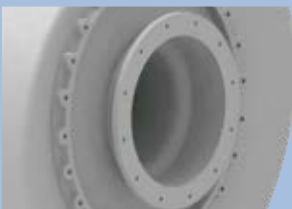

Flange connection
P. 49



Shaft seal
felt ring
P. 50



Shaft seal
Viton/Hastelloy
P. 50



Protection grid
P. 51

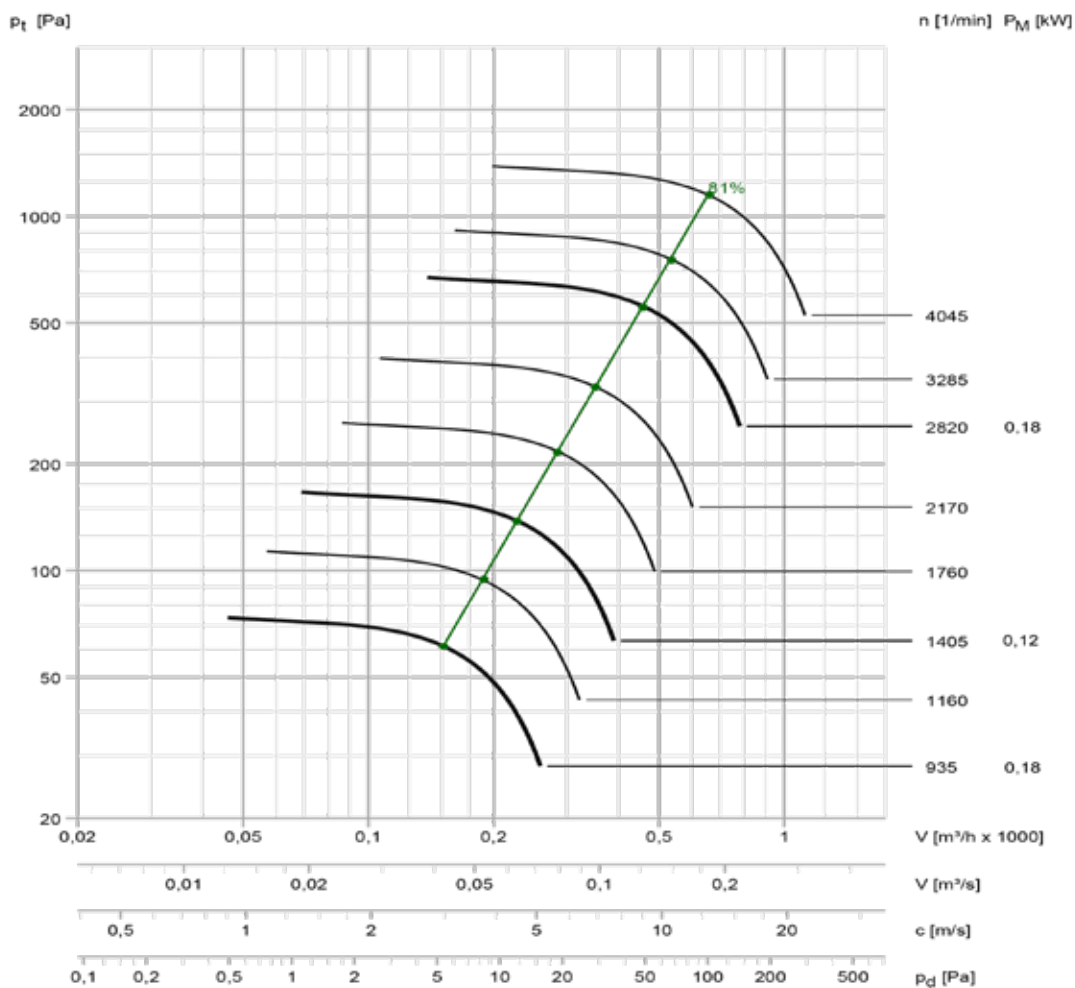

= 50 Hz mains operation
 = Continuous intermediate values through optional frequency inverter

Acoustic level according to VDI 3731									
Speed [1/min]	Inlet level / outlet level of the duct sound level non-valuated; Lw3 = Lw4 [dB]								Lp2A (1 m) [dB(A)]
	63	125	250	500	1000	2000	4000	8000	
4045	88	88	86	84	79	73	6	57	69
3285	83	83	82	77	73	66	59	49	63
2820	80	79	78	73	68	62	54	44	59
2170	75	73	71	66	61	53	45	35	52
1760	70	69	65	60	54	47	38	27	46
1405	65	64	59	54	47	39	30	19	40
1160	61	59	54	49	42	33	23	12	35
935	56	54	49	43	35	26	16	4	30



Repair switch
P. 54



Motor cover
P. 51



Sound enclosure
P. 53



Fans optionally available
for Ex-Zone!
P. 56

HF - Centrifugal fan
Type series HF R ...-17 D

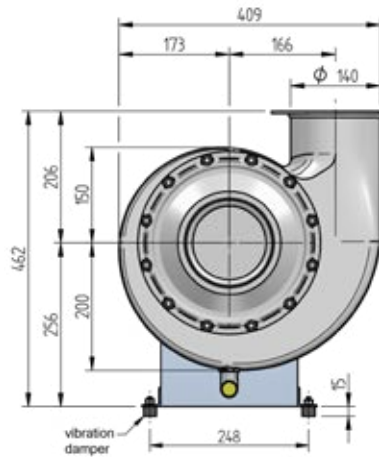

Direct drive

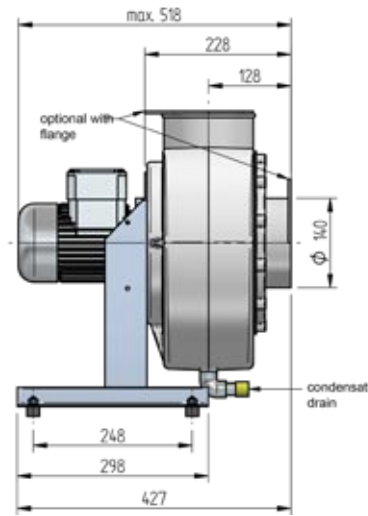

Accessories:

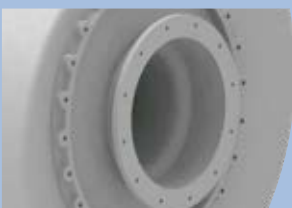

Flange connection
P. 49



Shaft seal
felt ring
P. 50



Shaft seal
Viton/Hastelloy
P. 50



Protection grid
P. 51

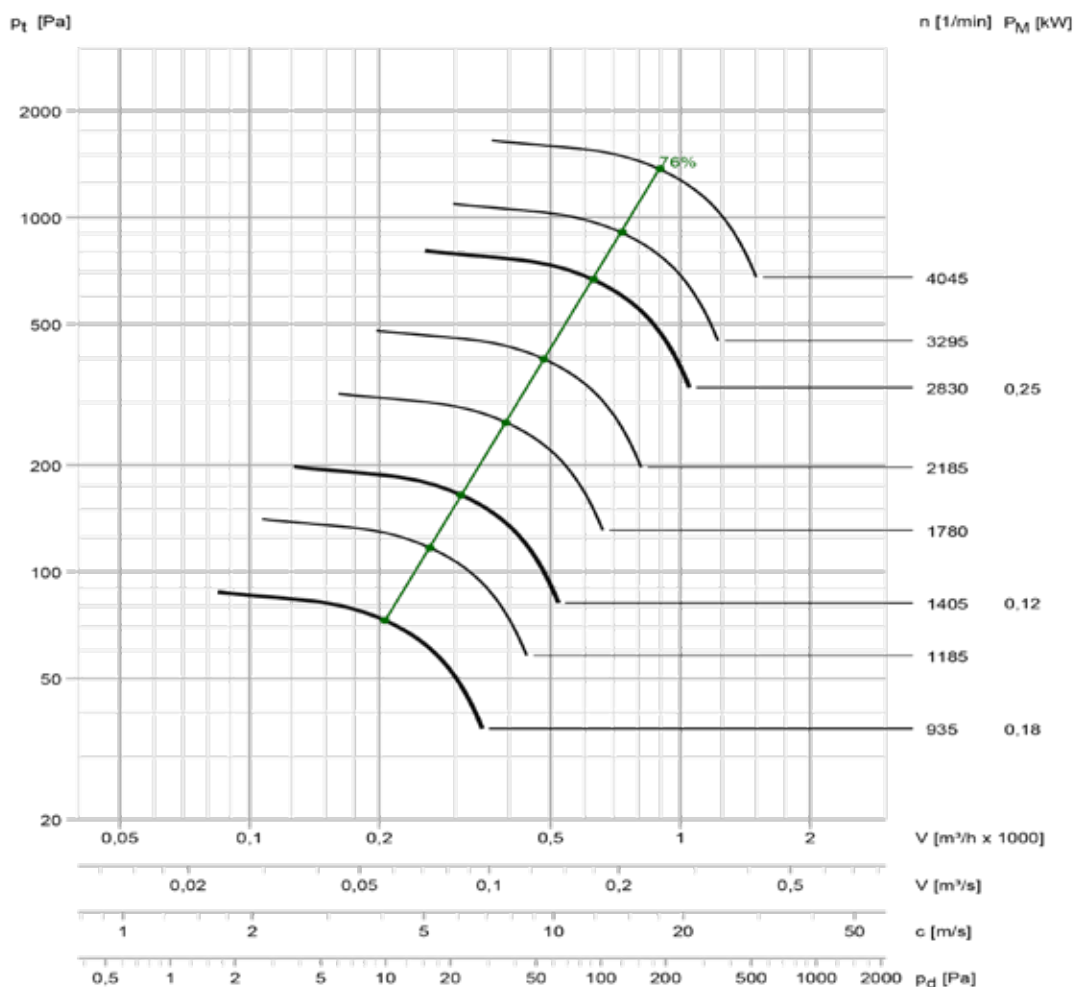

= 50 Hz mains operation
 = Continuous intermediate values through optional frequency inverter

Acoustic level according to VDI 3731									
Speed [1/min]	Inlet level / outlet level of the duct sound level non-valuated; Lw3 = Lw4 [dB]								Lp2A (1 m) [dB(A)]
	63	125	250	500	1000	2000	4000	8000	
4045	94	94	93	102	89	85	81	75	83
3295	89	89	97	85	82	78	73	68	75
2830	86	85	94	81	78	74	69	63	71
2185	80	79	87	75	71	67	61	55	65
1780	74	83	71	68	64	59	54	47	56
1405	69	77	65	62	58	53	47	40	50
1185	65	73	61	57	53	48	41	34	45
935	59	67	55	51	46	41	34	27	39



Repair switch
P. 54



Motor cover
P. 51



Sound enclosure
P. 53



Fans optionally available
for Ex-Zone!
P. 56

HF - Centrifugal fan
Type series HF R ...-15 D / R

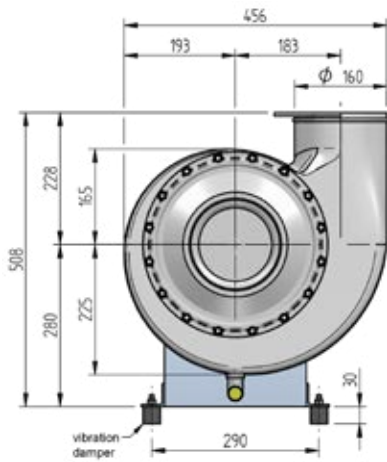

Direct drive

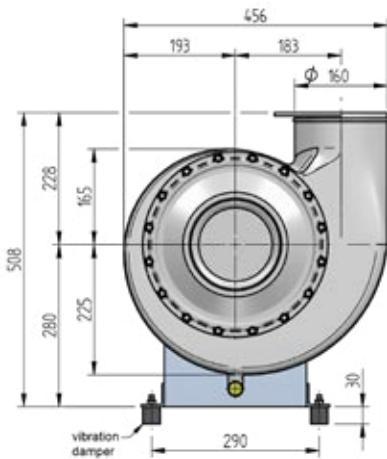
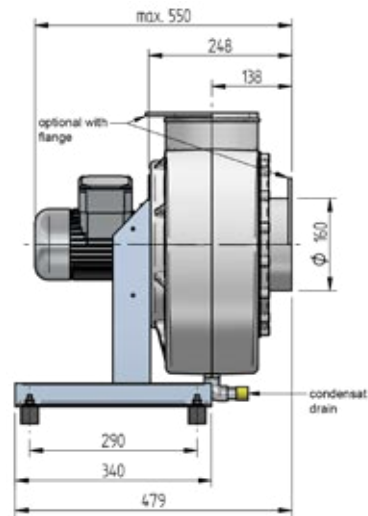

Belt drive (RF)

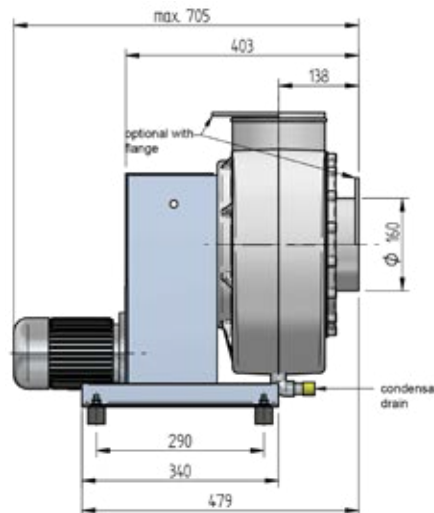

Accessories:

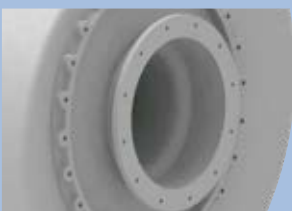

Flange connection
P. 49



Shaft seal
felt ring
P. 50



Shaft seal
Viton/Hastelloy
P. 50



Protection grid
P. 51

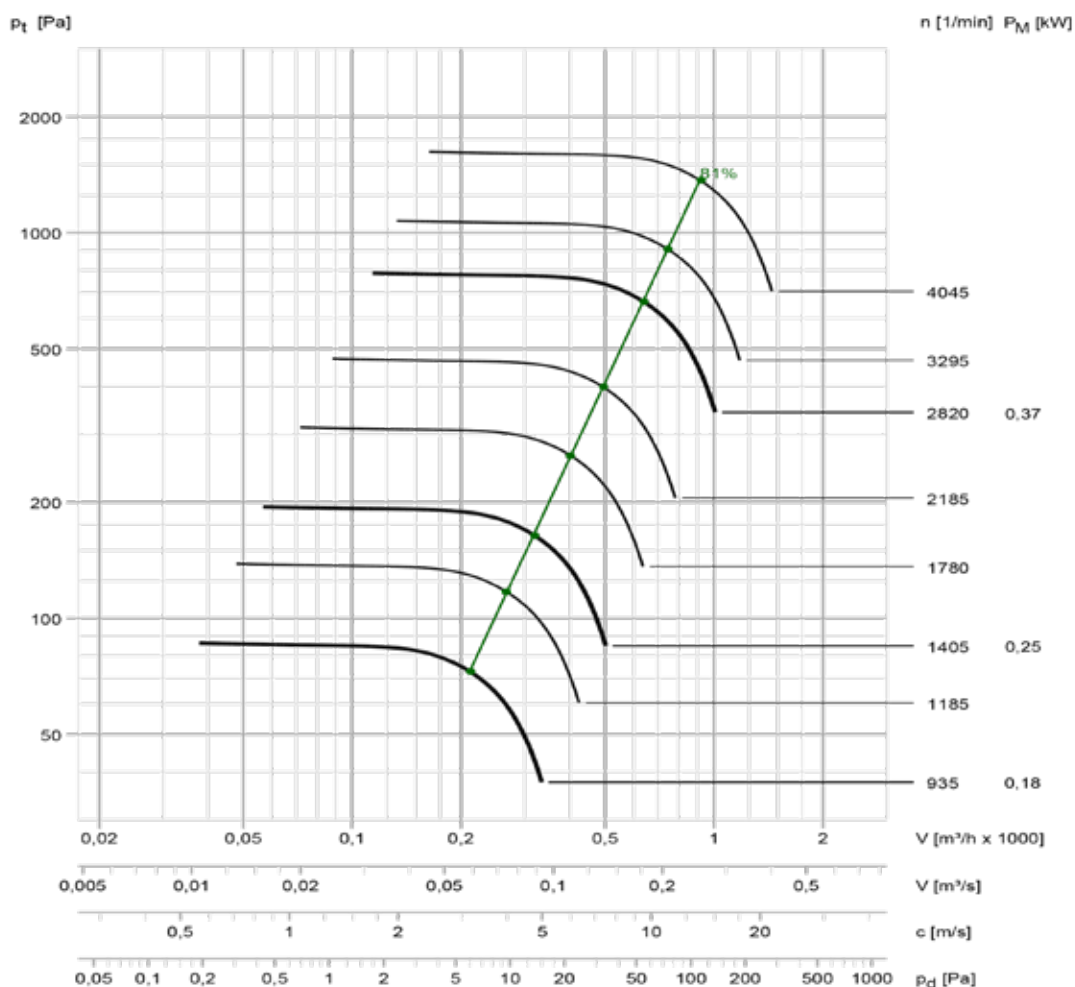

= 50 Hz mains operation
 = Continuous intermediate values through optional frequency inverter

Acoustic level according to VDI 3731									
Speed [1/min]	Inlet level / outlet level of the duct sound level non-valuated; Lw3 = Lw4 [dB]								Lp2A (1 m) [dB(A)]
	63	125	250	500	1000	2000	4000	8000	
4045	91	91	89	87	82	76	69	60	72
3295	87	86	85	81	76	70	62	53	66
2820	83	83	81	77	71	65	57	47	62
2185	78	77	75	70	64	57	48	38	55
1780	74	73	69	64	58	50	41	31	50
1405	69	67	63	57	51	43	33	22	43
1185	65	63	58	53	46	37	27	16	39
935	60	58	52	46	39	30	19	7	33



Repair switch
P. 54



Motor cover
P. 51



Sound enclosure
P. 53



Fans optionally available for Ex-Zone!
P. 56

HF - Centrifugal fan
 Type series HF R ...-17 D / R
 optional for ATEX zone 1
 in GR ...

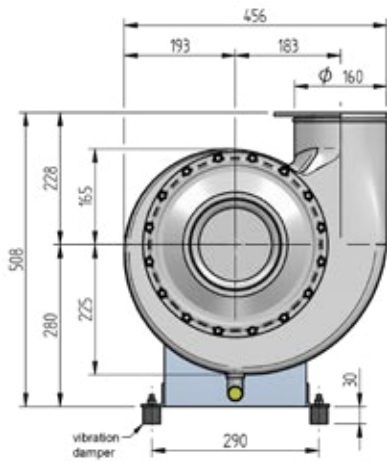

Direct drive

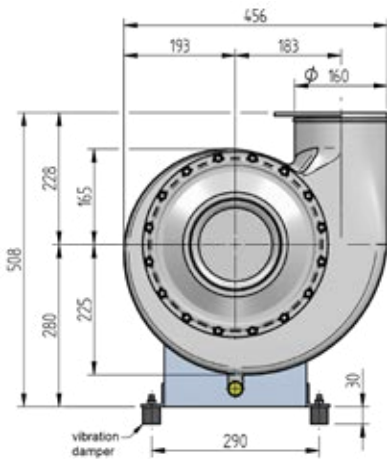
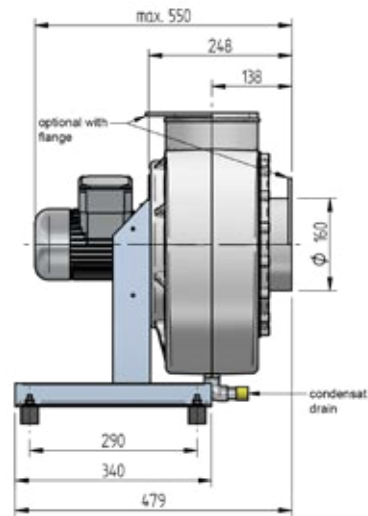

Belt drive (RF)

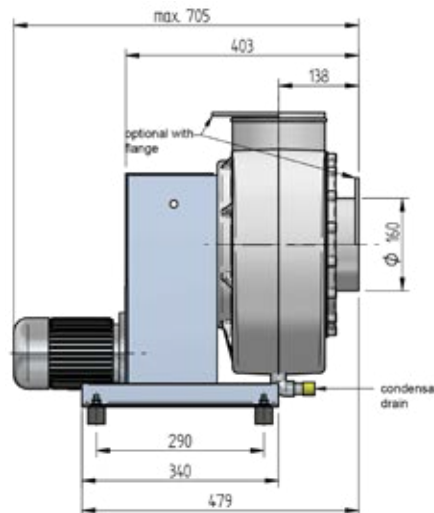

Accessories:

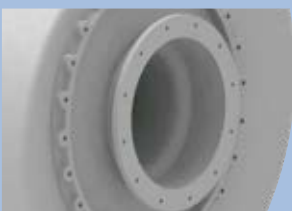

Flange connection
 P. 49



Shaft seal
 felt ring
 P. 50



Shaft seal
 Viton/Hastelloy
 P. 50



Protection grid
 P. 51

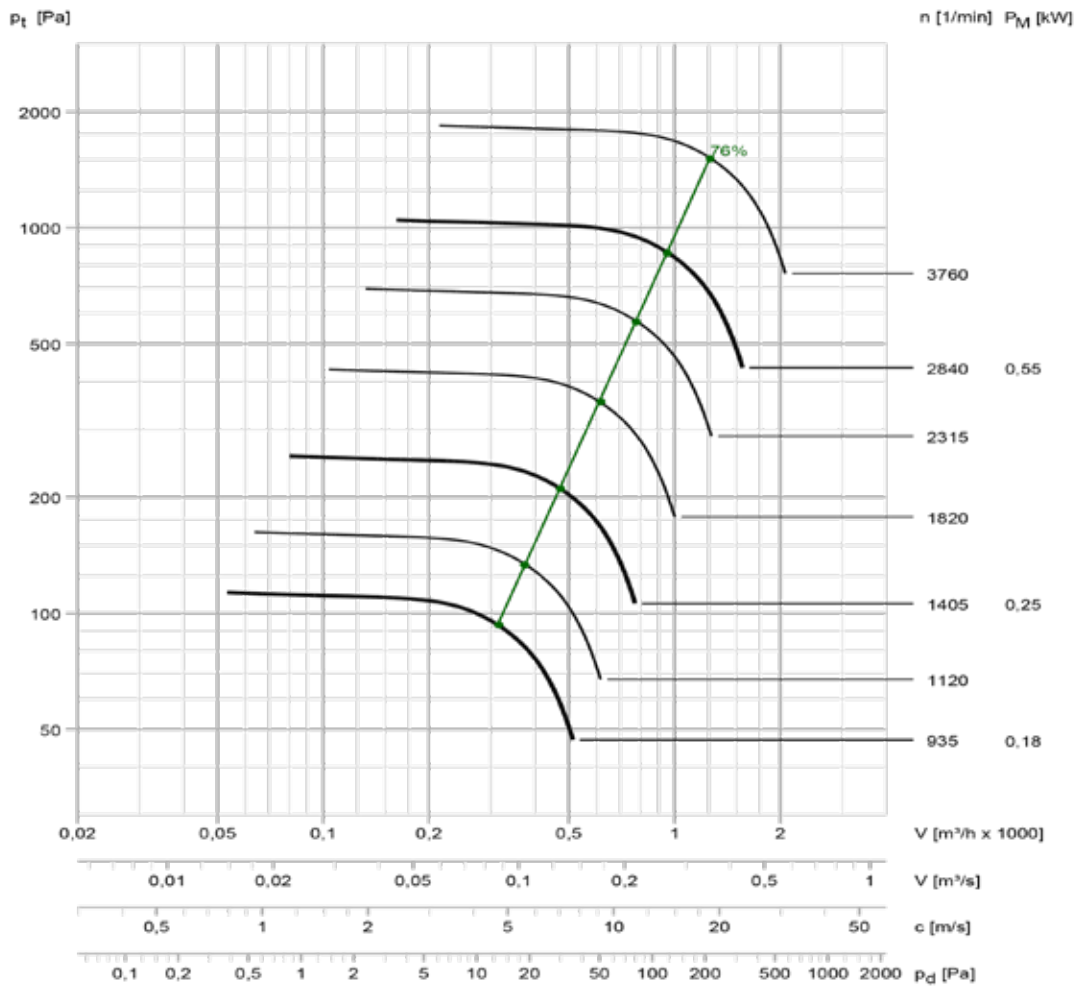

= 50 Hz mains operation
 = Continuous intermediate values through optional frequency inverter

Acoustic level according to VDI 3731									
Speed [1/min]	Inlet level / outlet level of the duct sound level non-valuated; Lw3 = Lw4 [dB]								Lp2A (1 m) [dB(A)]
	63	125	250	500	1000	2000	4000	8000	
3760	100	100	99	98	95	91	86	81	83
2840	94	94	93	90	87	83	78	72	76
2315	90	89	88	85	81	77	72	65	70
1820	84	83	82	78	75	70	64	58	64
1405	78	78	75	71	67	62	56	49	57
1120	73	72	69	65	61	56	49	42	51
935	69	68	64	61	56	50	44	36	46



Repair switch
P. 54



Motor cover
P. 51



Sound enclosure
P. 53



Fans optionally available
for Ex-Zone!
P. 56

HF - Centrifugal fan
Type series HF R ...-15 D / R

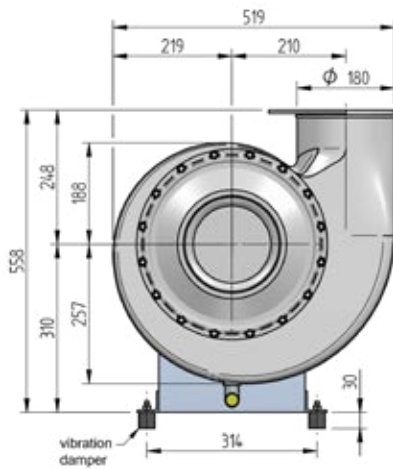

Direct drive

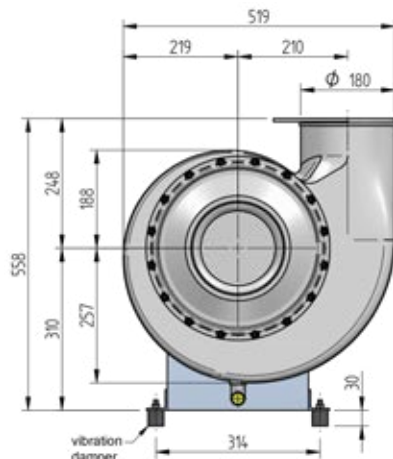
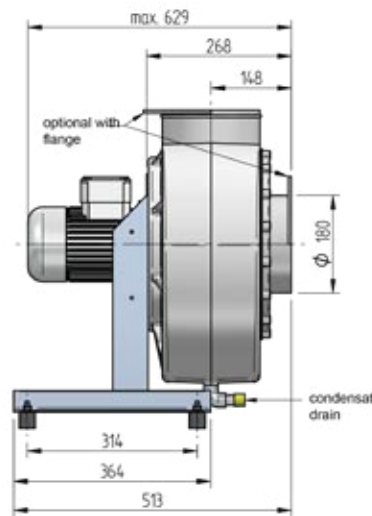

Belt drive (RF)

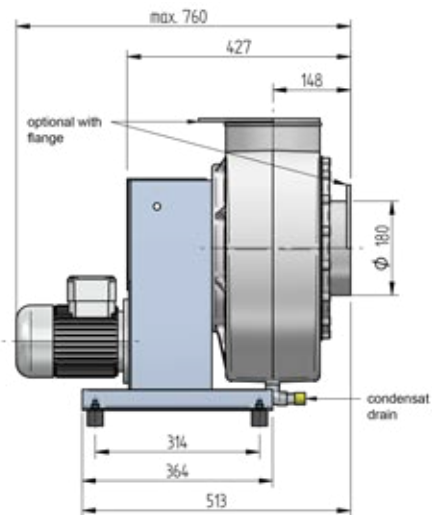

Accessories:

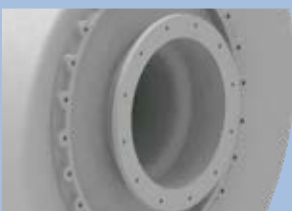

Flange connection
P. 49



Shaft seal
felt ring
P. 50



Shaft seal
Viton/Hastelloy
P. 50



Protection grid
P. 51

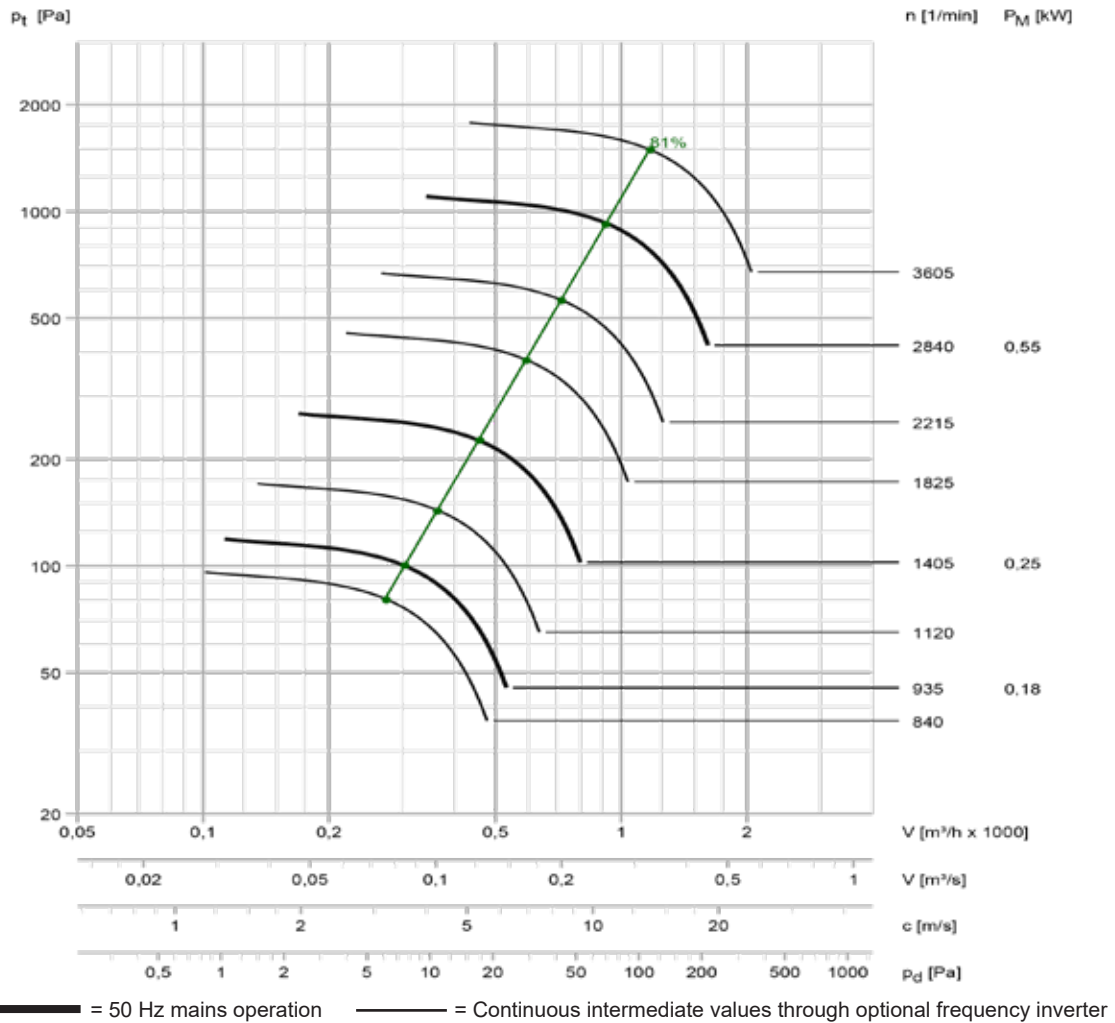

Acoustic level according to VDI 3731									
Speed [1/min]	Inlet level / outlet level of the duct sound level non-valuated; Lw3 = Lw4 [dB]								Lp2A (1 m) [dB(A)]
	63	125	250	500	1000	2000	4000	8000	
3605	90	90	88	95	80	74	67	58	76
2840	84	83	91	77	72	65	57	48	67
2215	79	77	85	70	65	58	49	39	61
1825	75	73	80	65	59	52	43	32	57
1405	67	75	61	56	50	42	32	21	46
1120	63	70	56	50	43	34	24	13	40
935	59	66	51	45	38	29	18	6	36
840	64	51	46	39	32	23	12	0	28



Repair switch
P. 54



Motor cover
P. 51



Sound enclosure
P. 53



Fans optionally available for Ex-Zone!
P. 56

HF - Centrifugal fan
Type series HF R ...-17 D / R

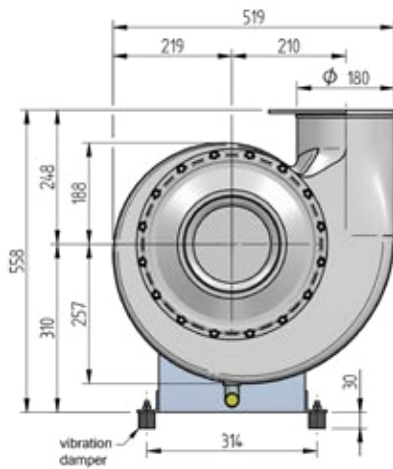

Direct drive

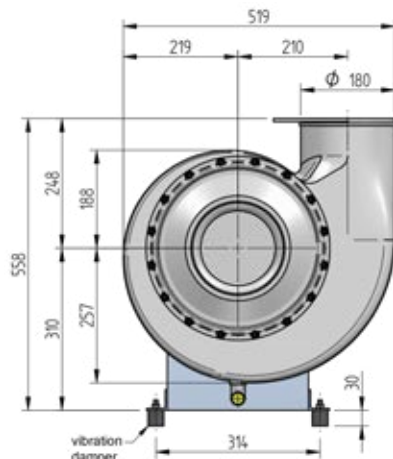
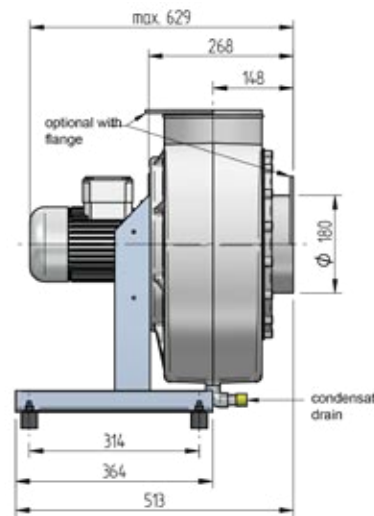

Belt drive (RF)

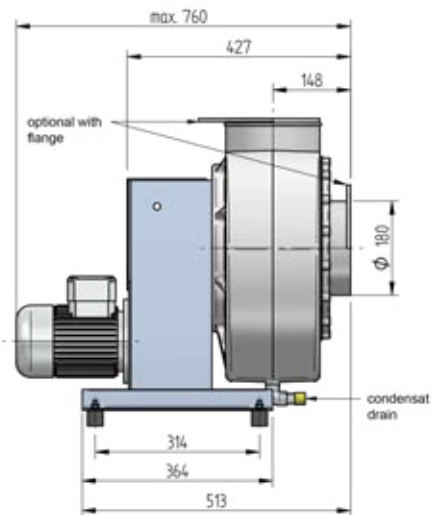

Accessories:

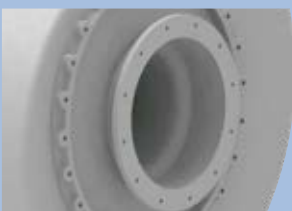

Flange connection
P. 49



Shaft seal
felt ring
P. 50



Shaft seal
Viton/Hastelloy
P. 50



Protection grid
P. 51

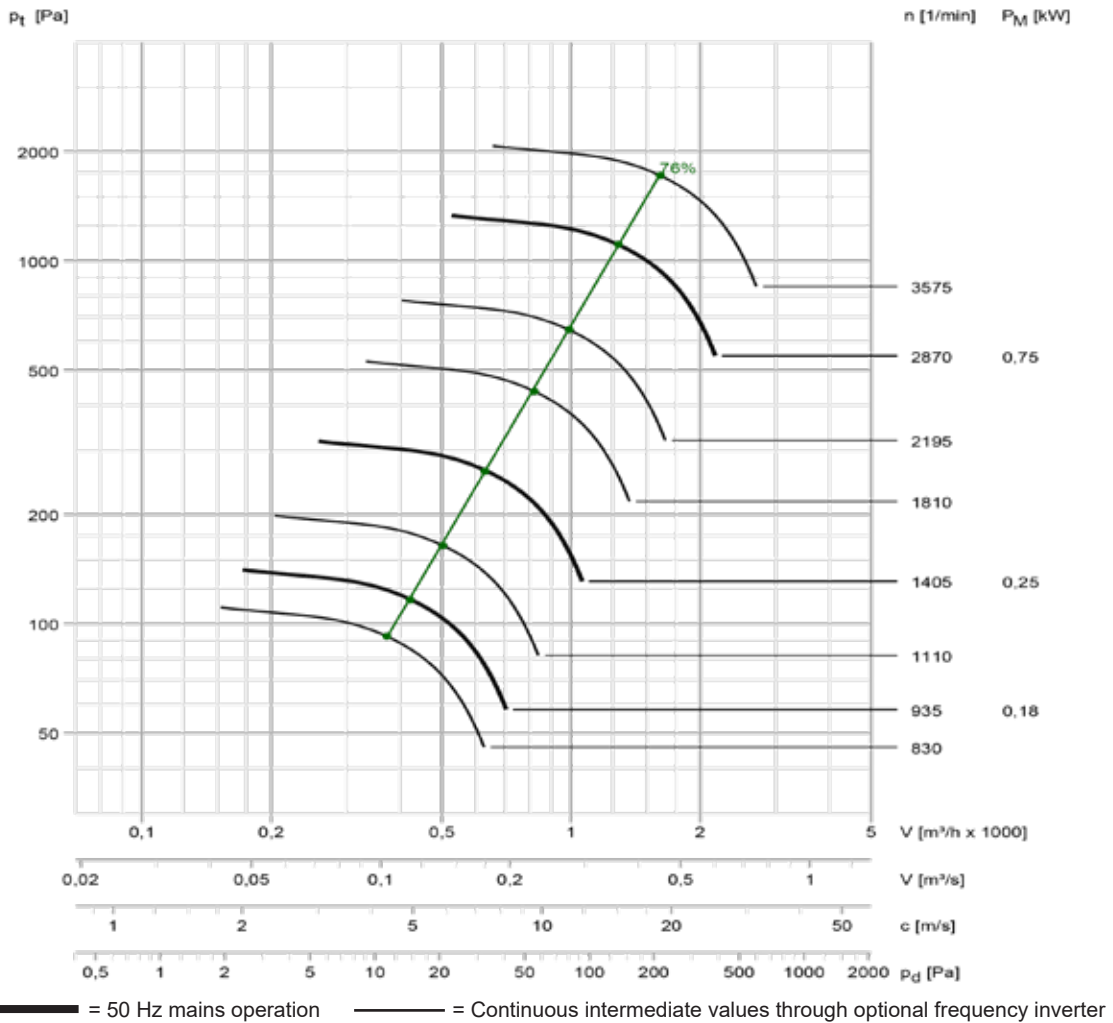

Acoustic level according to VDI 3731									
Speed [1/min]	Inlet level / outlet level of the duct sound level non-valuated; Lw3 = Lw4 [dB]								Lp2A (1 m) [dB(A)]
	63	125	250	500	1000	2000	4000	8000	
3575	100	99	98	106	93	90	85	79	87
2870	94	93	102	89	86	82	77	71	79
2195	88	87	95	83	79	75	69	63	72
1810	84	82	90	78	74	69	63	57	67
1405	76	85	73	69	65	60	54	48	57
1110	71	79	67	63	59	53	47	40	51
935	67	75	62	59	54	48	42	35	47
830	73	61	58	54	49	43	37	29	40



Repair switch
P. 54



Motor cover
P. 51



Sound enclosure
P. 53



Fans optionally available
for Ex-Zone!
P. 56

HF - Centrifugal fan
Type series HF R ...-15 D / R

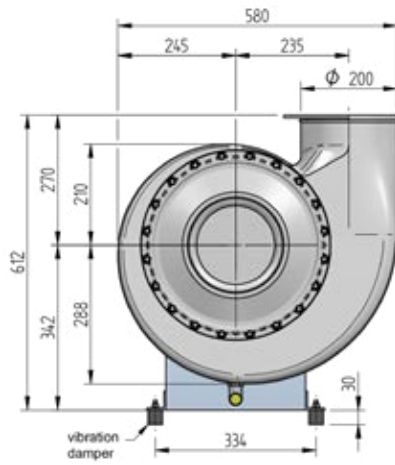

Direct drive

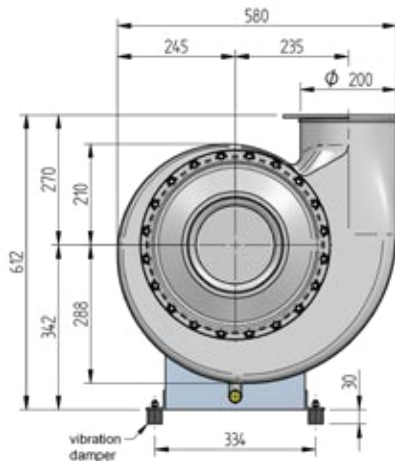
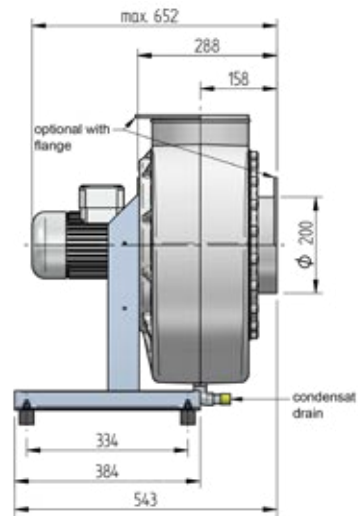

Belt drive (RF)

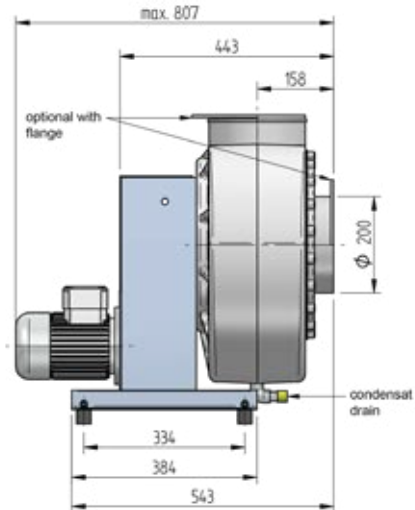

Accessories:

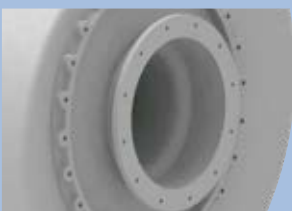

Flange connection
P. 49



Shaft seal
felt ring
P. 50



Shaft seal
Viton/Hastelloy
P. 50



Protection grid
P. 51

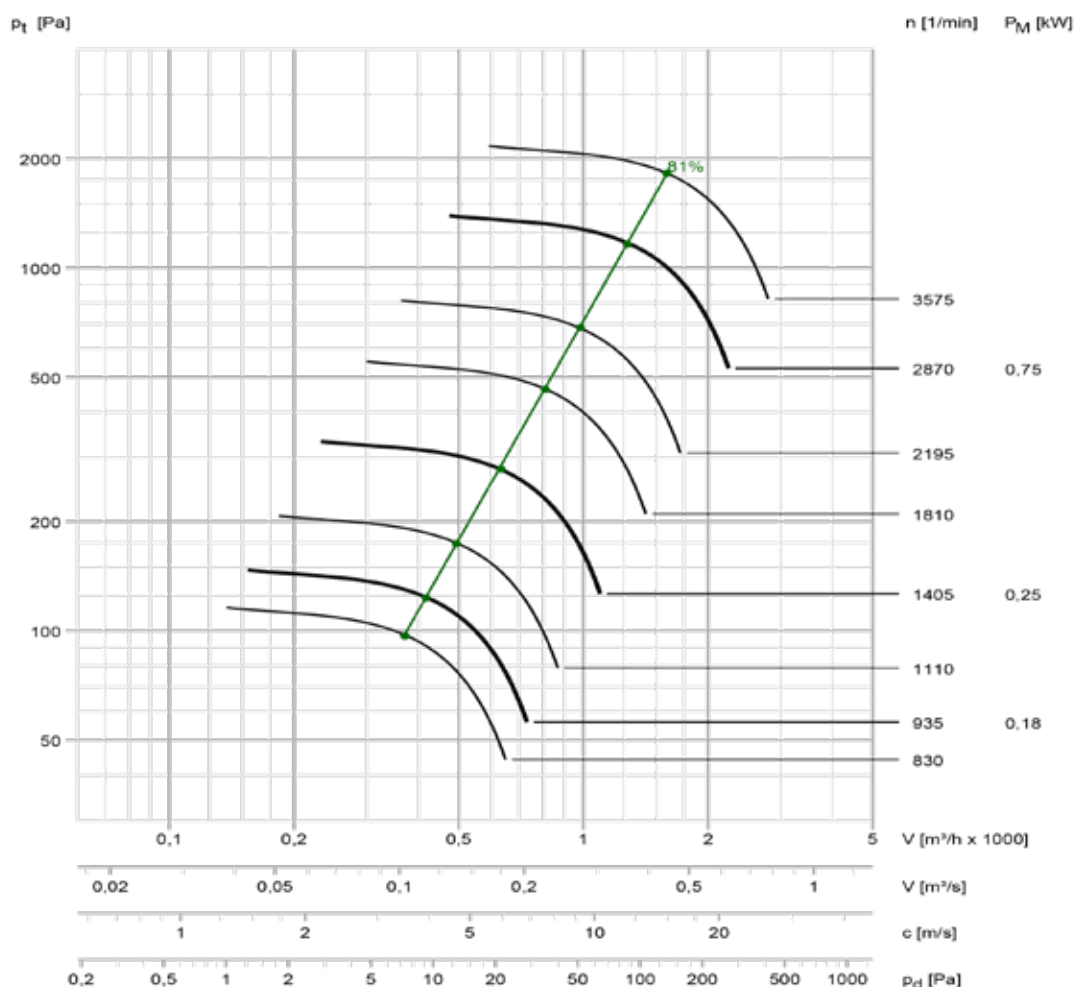

= 50 Hz mains operation
 = Continuous intermediate values through optional frequency inverter

Acoustic level according to VDI 3731									
Speed [1/min]	Inlet level / outlet level of the duct sound level non-valuated; Lw3 = Lw4 [dB]								Lp2A (1 m) [dB(A)]
	63	125	250	500	1000	2000	4000	8000	
3575	93	93	91	98	83	77	70	61	79
2870	87	86	94	81	75	69	61	51	71
2195	82	81	88	74	68	61	52	42	64
1810	78	76	83	69	62	55	46	36	59
1405	71	78	65	60	53	45	35	24	49
1110	66	73	59	53	46	37	27	16	43
935	62	69	54	48	41	32	22	10	39
830	67	54	49	42	35	26	15	3	30



Repair switch
P. 54



Motor cover
P. 51



Sound enclosure
P. 53



Fans optionally available for Ex-Zone!
P. 56

HF - Centrifugal fan
 Type series HF R ...-17 D / R
 optional for ATEX zone 1
 in GR ...

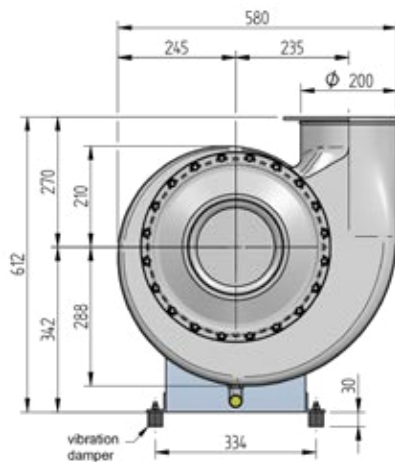

Direct drive

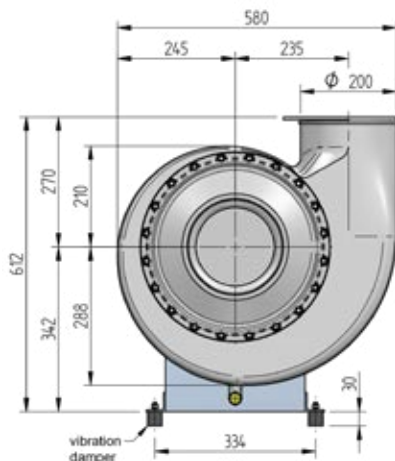
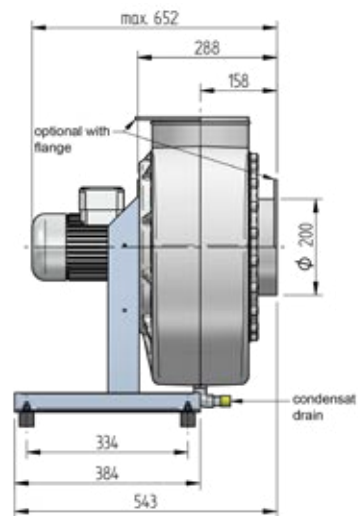

Belt drive (RF)

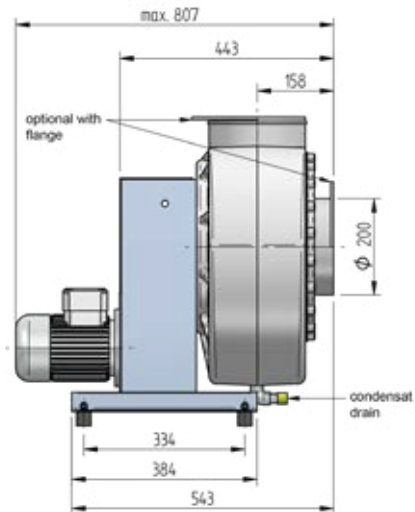

Accessories:

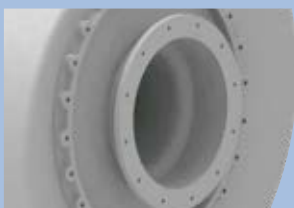

Flange connection
 P. 49



Shaft seal
 felt ring
 P. 50



Shaft seal
 Viton/Hastelloy
 P. 50



Protection grid
 P. 51

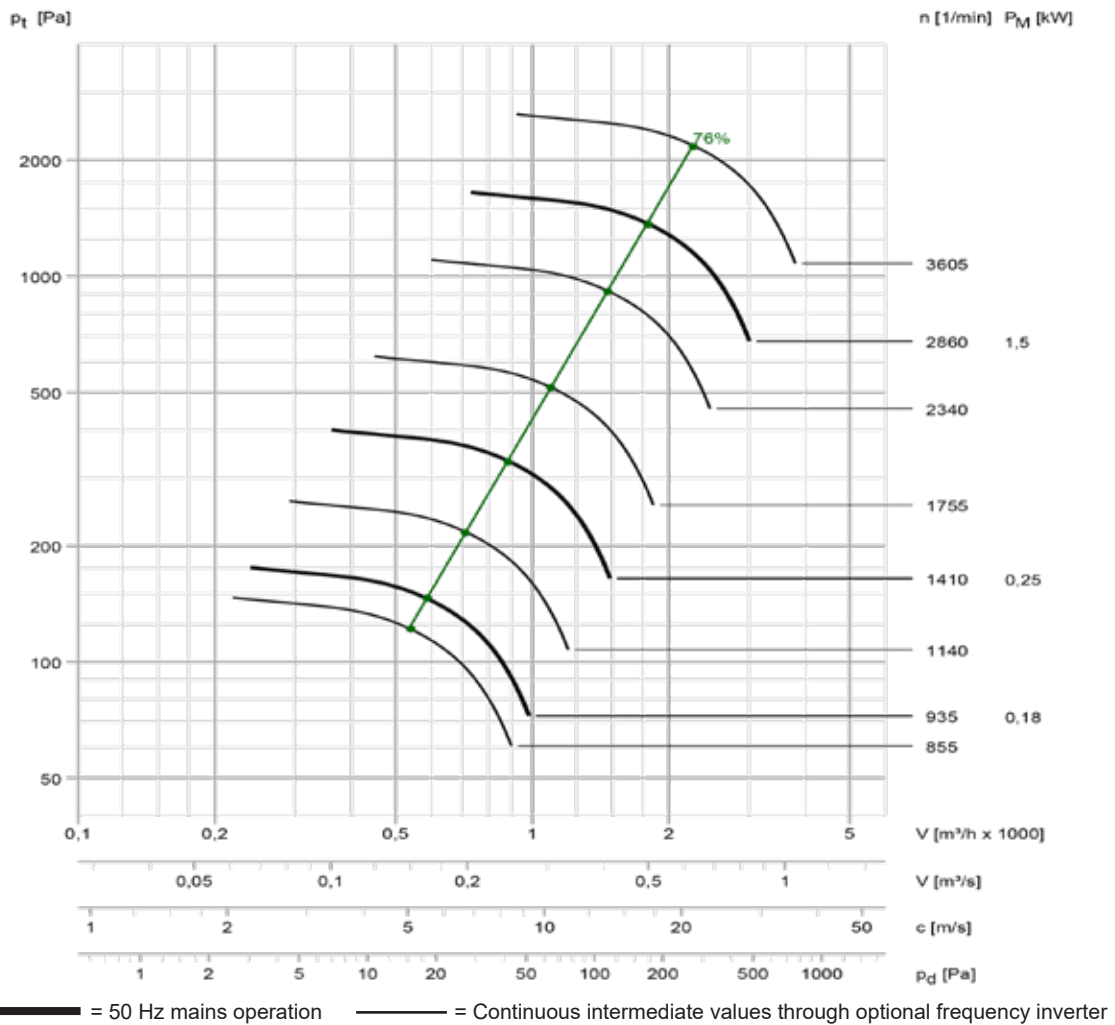

Acoustic level according to VDI 3731									
Speed [1/min]	Inlet level / outlet level of the duct sound level non-valuated; Lw3 = Lw4 [dB]								Lp2A (1 m) [dB(A)]
	63	125	250	500	1000	2000	4000	8000	
3605	103	103	102	110	97	93	89	83	91
2860	97	97	105	93	90	86	81	75	82
2340	93	92	100	88	84	80	75	69	77
1755	85	94	82	79	75	70	65	58	66
1410	80	89	76	73	69	64	58	51	60
1140	75	84	71	68	63	58	52	44	55
935	71	79	66	62	58	52	46	38	50
855	77	65	62	58	53	48	41	34	44



Repair switch
P. 54



Motor cover
P. 51



Sound enclosure
P. 53



Fans optionally available for Ex-Zone!
P. 56

HF - Centrifugal fan
Type series HF R ...-15 D / R

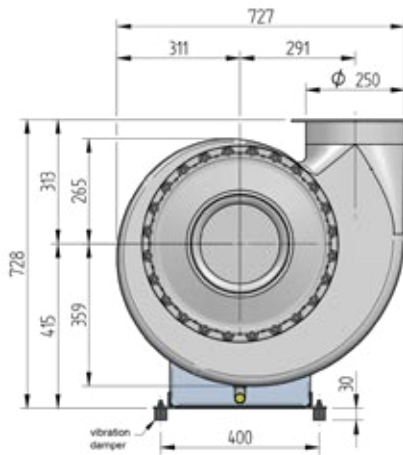

Direct drive

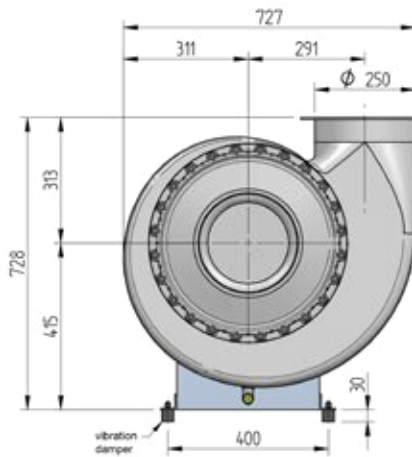
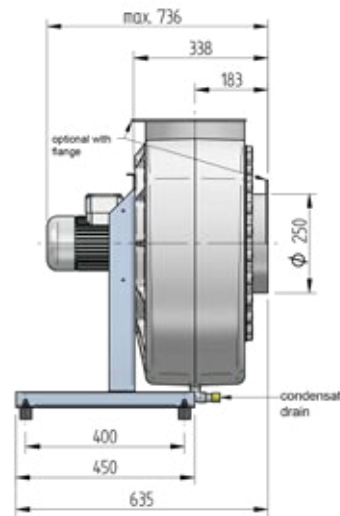

Belt drive (RF)

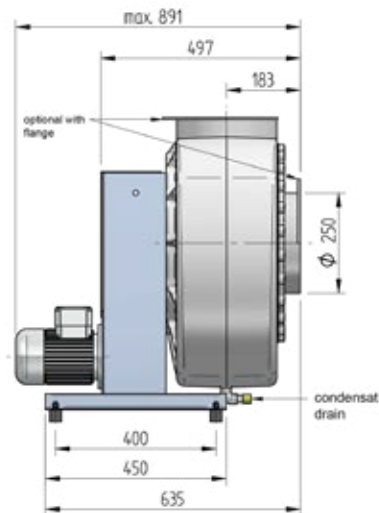

Accessories:

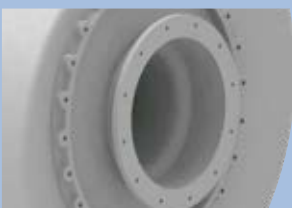

Flange connection
P. 49



Shaft seal
felt ring
P. 50



Shaft seal
Viton/Hastelloy
P. 50



Protection grid
P. 51

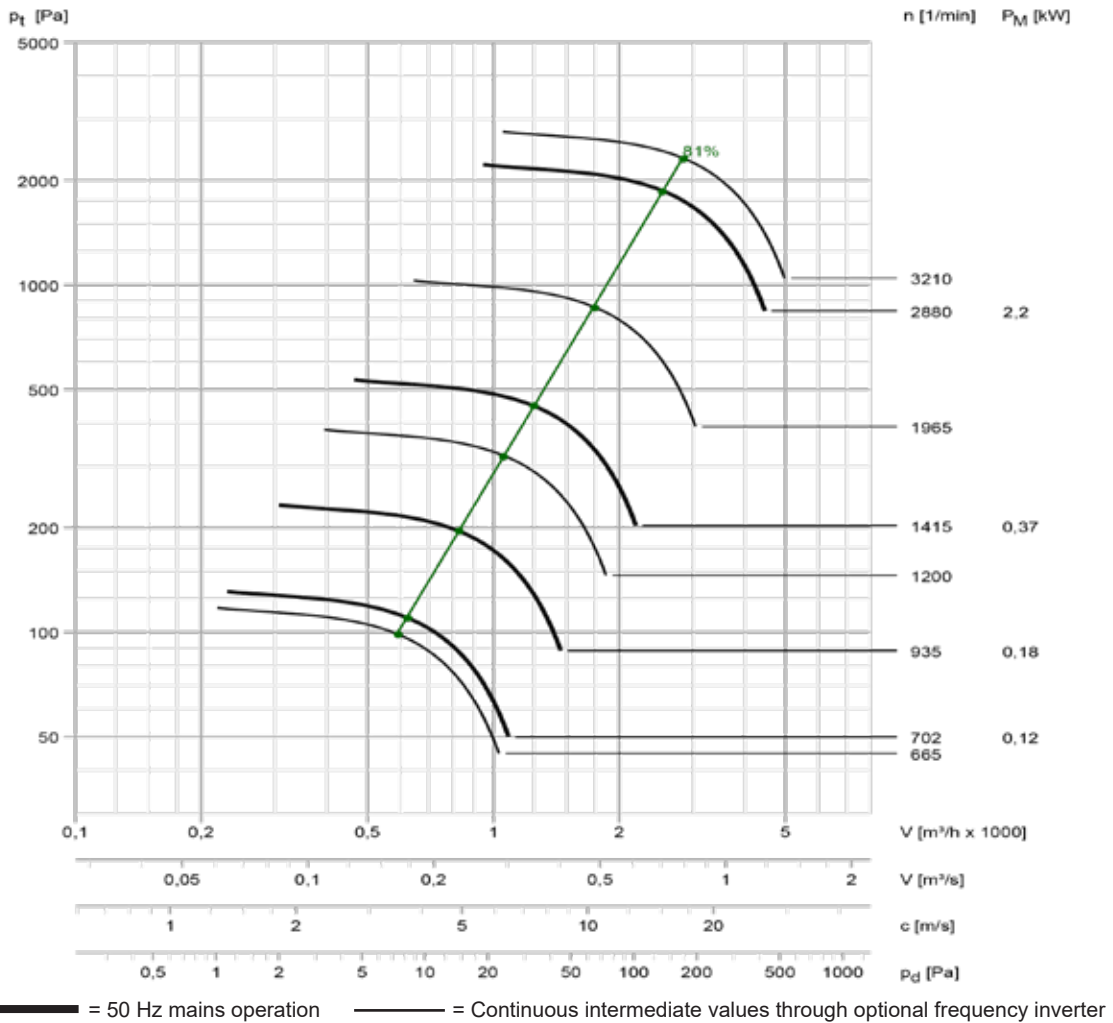

Acoustic level according to VDI 3731									
Speed [1/min]	Inlet level / outlet level of the duct sound level non-valuated; Lw3 = Lw4 [dB]								Lp2A (1 m) [dB(A)]
	63	125	250	500	1000	2000	4000	8000	
3210	97	96	104	91	86	79	72	62	80
2880	95	94	102	88	83	76	68	59	77
1965	87	85	92	78	72	65	56	46	68
1415	75	86	72	67	60	52	43	32	56
1200	75	82	68	62	56	47	37	26	52
935	69	76	62	56	48	39	29	17	46
702	70	57	51	45	37	27	16	4	33
665	69	55	50	43	35	25	14	2	31



Repair switch
P. 54



Motor cover
P. 51



Sound enclosure
P. 53



Fans optionally available
for Ex-Zone!
P. 56

HF - Centrifugal fan
 Type series HF R ...-17 D / R
 optional for ATEX zone 1
 in GR ...

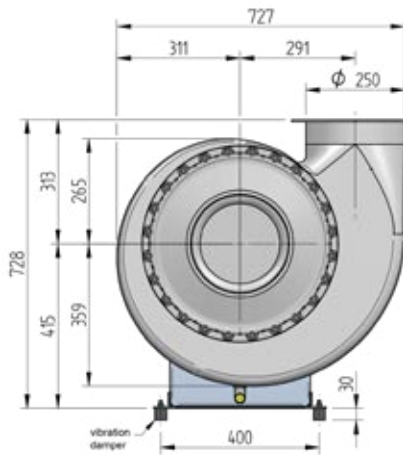

Direct drive

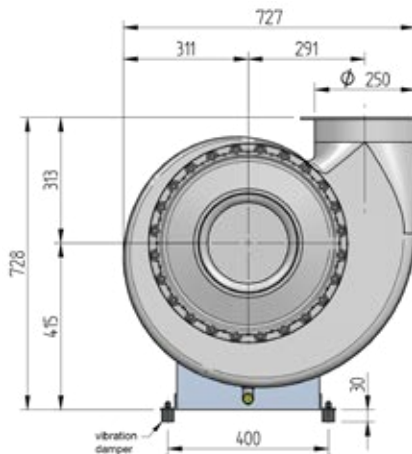
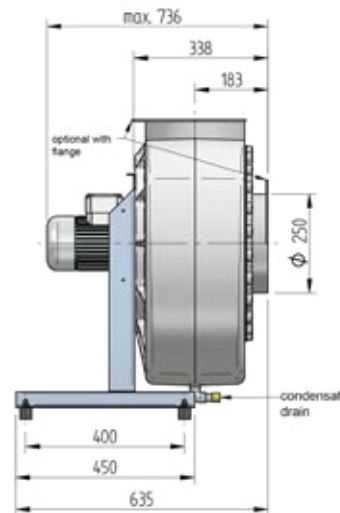

Belt drive (RF)

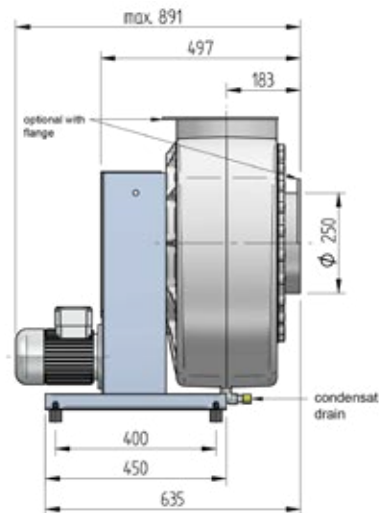

Accessories:

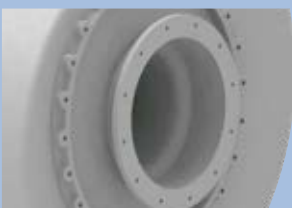

Flange connection
 P. 49



Shaft seal
 felt ring
 P. 50



Shaft seal
 Viton/Hastelloy
 P. 50



Protection grid
 P. 51

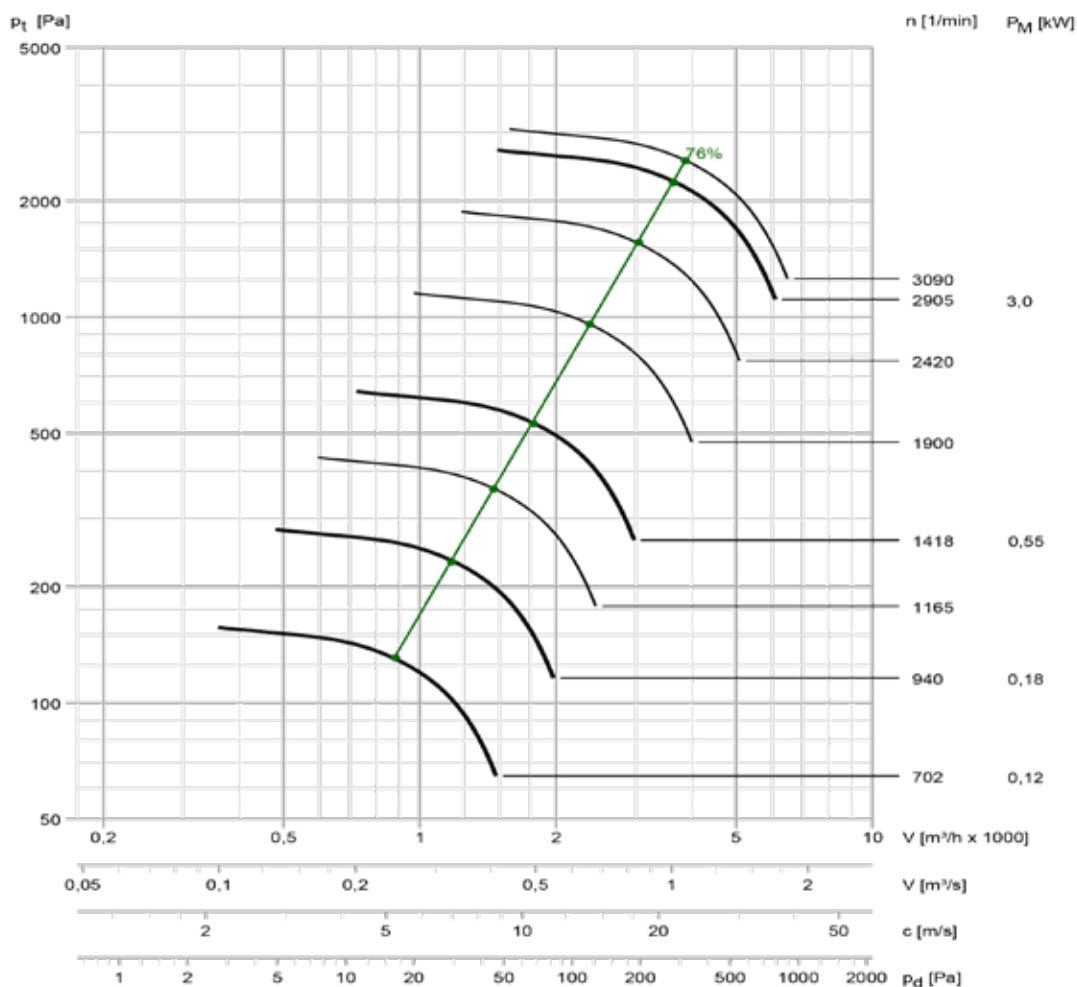

= 50 Hz mains operation
 = Continuous intermediate values through optional frequency inverter

Acoustic level according to VDI 3731									
Speed [1/min]	Inlet level / outlet level of the duct sound level non-valuated; Lw3 = Lw4 [dB]								Lp2A (1 m) [dB(A)]
	63	125	250	500	1000	2000	4000	8000	
3090	106	106	115	102	99	95	90	85	91
2905	105	105	113	101	98	94	89	83	90
2420	101	100	109	96	93	88	83	77	85
1900	96	95	103	90	86	82	76	70	79
1418	88	96	84	81	77	72	66	59	68
1165	83	92	79	76	71	66	60	53	63
940	78	87	74	70	65	60	53	46	57
702	80	68	64	60	55	49	43	35	46



Repair switch
P. 54



Motor cover
P. 51



Sound enclosure
P. 53



Fans optionally available
for Ex-Zone!
P. 56

HF - Centrifugal fan
Type series HF R ...-15 D / R

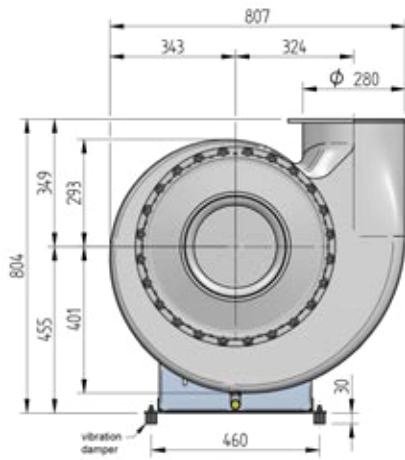

Direct drive

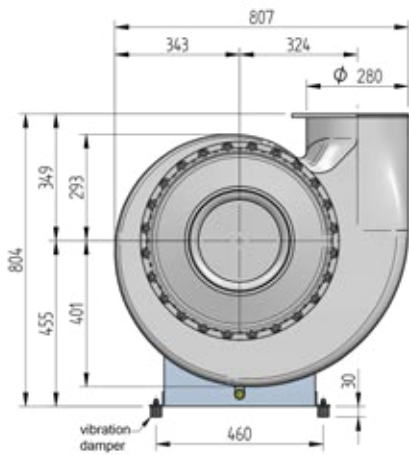
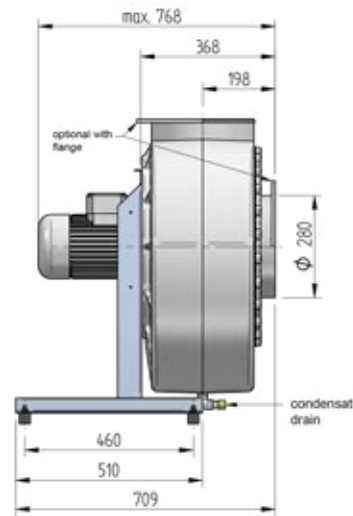

Belt drive (RF)

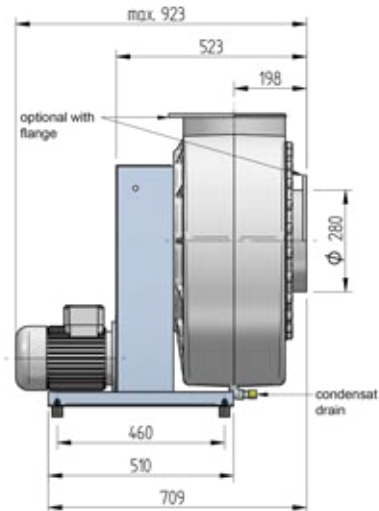

Accessories:

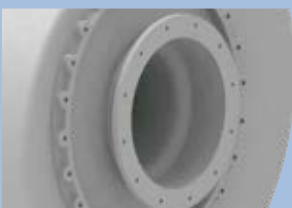

Flange connection
P. 49



Shaft seal
felt ring
P. 50



Shaft seal
Viton/Hastelloy
P. 50



Protection grid
P. 51

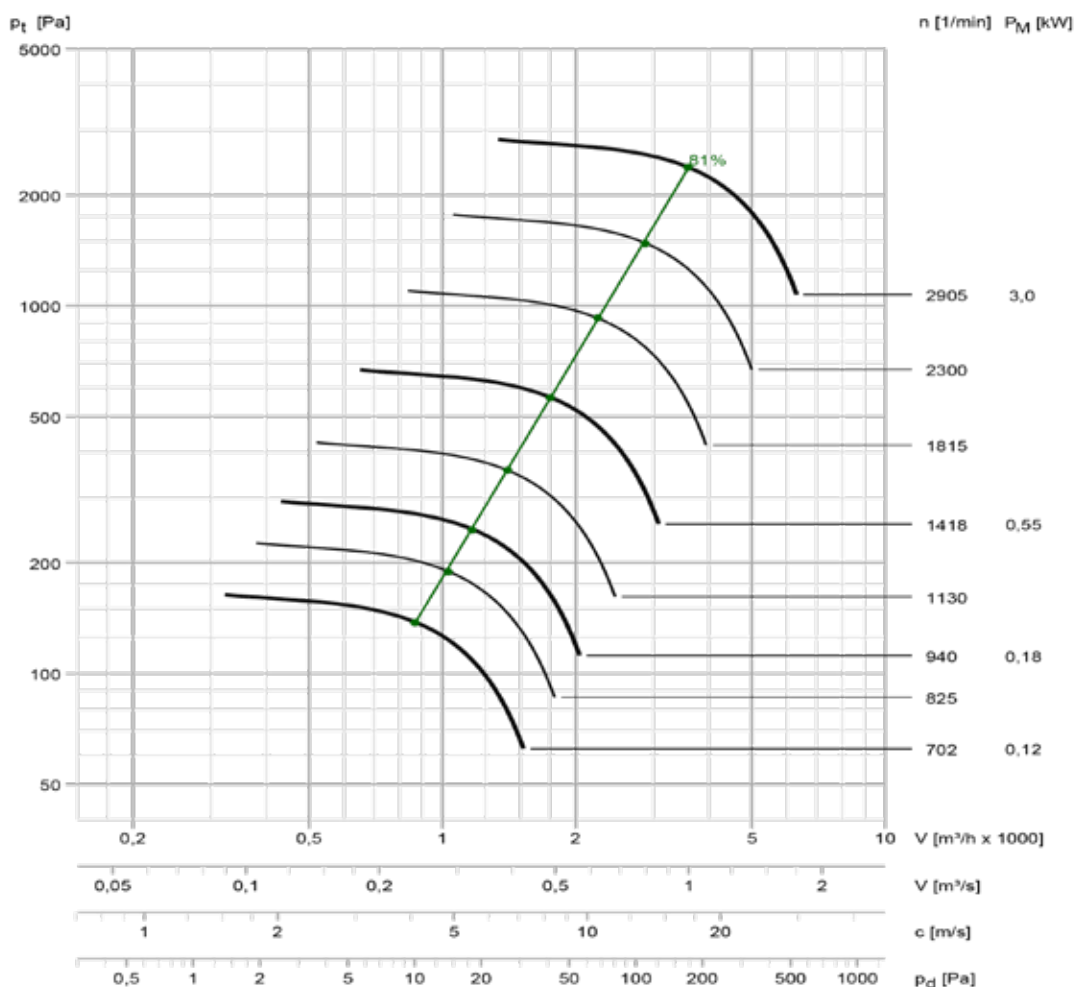

= 50 Hz mains operation
 = Continuous intermediate values through optional frequency inverter

Acoustic level according to VDI 3731									
Speed [1/min]	Inlet level / outlet level of the duct sound level non-valuated; Lw3 = Lw4 [dB]								Lp2A (1 m) [dB(A)]
	63	125	250	500	1000	2000	4000	8000	
2905	98	98	105	92	87	80	72	63	81
2300	94	92	100	86	80	73	65	55	75
1815	89	87	94	79	73	66	57	46	70
1418	82	89	76	7	64	56	46	36	59
1130	77	84	70	64	57	49	39	27	54
940	73	80	65	59	52	43	33	21	49
825	78	64	59	53	45	36	26	14	40
702	74	60	55	48	40	31	20	7	36



Repair switch
P. 54



Motor cover
P. 51



Sound enclosure
P. 53



Fans optionally available
for Ex-Zone!
P. 56

HF - Centrifugal fan
Type series HF R ...-17 D / R

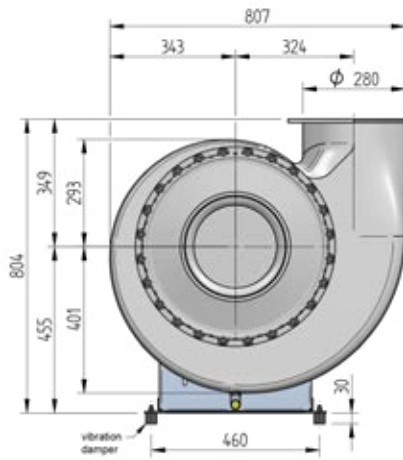

Direct drive

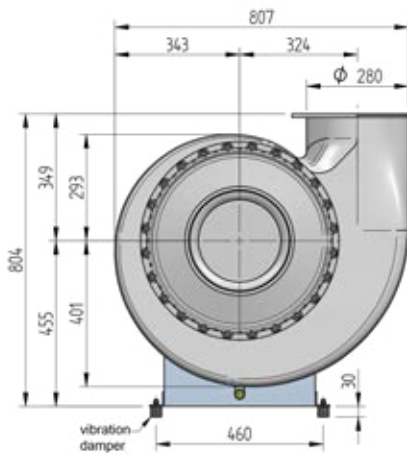
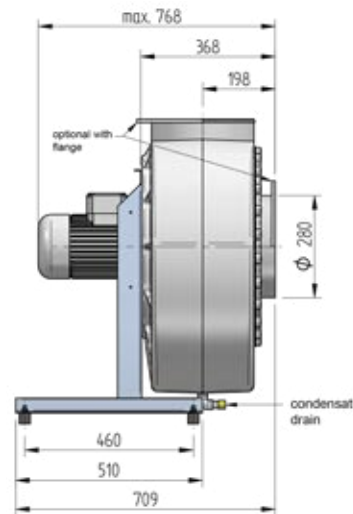

Belt drive (RF)

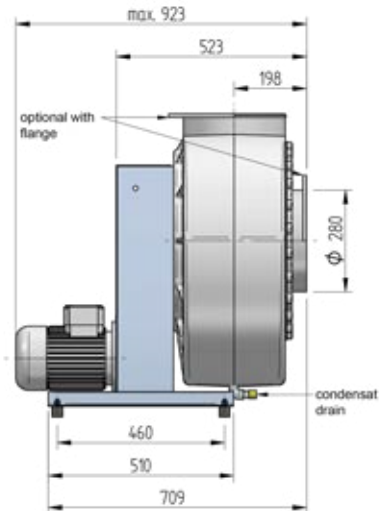

Accessories:

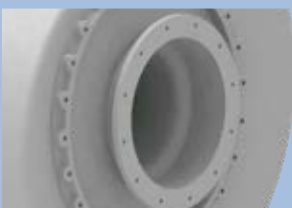

Flange connection
P. 49



Shaft seal
felt ring
P. 50



Shaft seal
Viton/Hastelloy
P. 50



Protection grid
P. 51

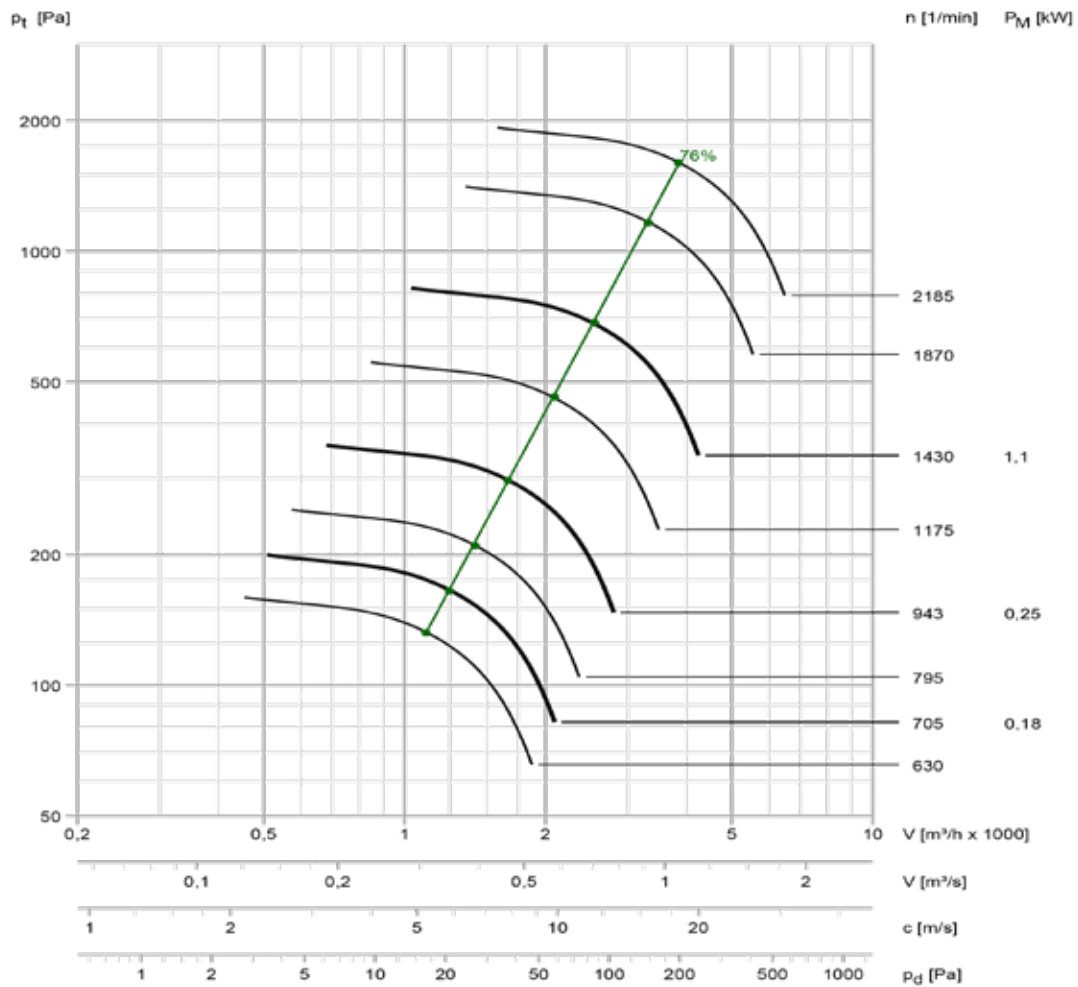

= 50 Hz mains operation
 = Continuous intermediate values through optional frequency inverter

Acoustic level according to VDI 3731									
Speed [1/min]	Inlet level / outlet level of the duct sound level non-valuated; Lw3 = Lw4 [dB]								Lp2A (1 m) [dB(A)]
	63	125	250	500	1000	2000	4000	8000	
2185	103	102	110	97	94	89	84	78	86
1870	99	98	106	93	90	85	79	73	82
1430	92	100	88	85	81	76	70	63	71
1175	87	96	83	80	75	70	64	57	66
943	82	90	78	74	69	64	57	50	61
795	87	75	72	68	63	57	50	43	52
705	84	72	68	64	59	53	46	39	49
630	81	69	65	61	56	50	43	35	46



Repair switch
P. 54



Motor cover
P. 51



Sound enclosure
P. 53



Fans optionally available
for Ex-Zone!
P. 56

HF - Centrifugal fan
 Type series HF R ...-15 D / R
 optional for ATEX zone 1
 in GR ...

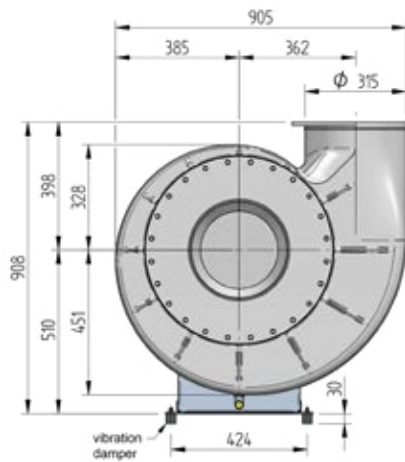

Direct drive

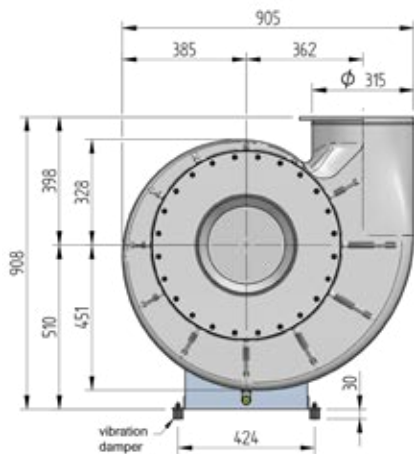
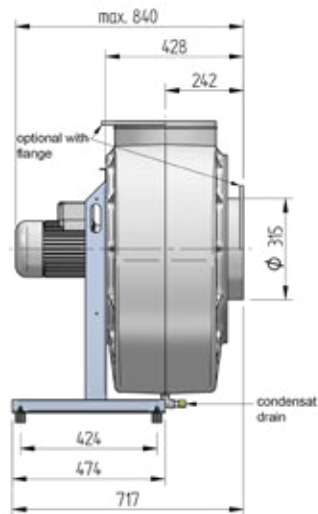

Belt drive (RF)

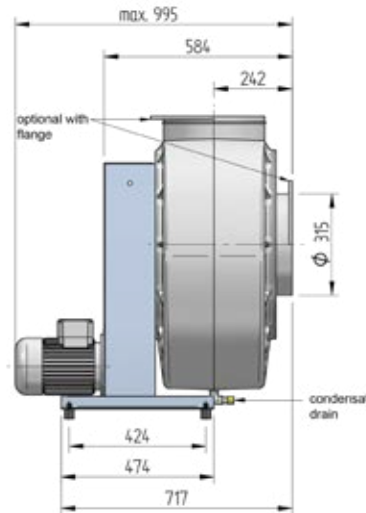

Accessories:

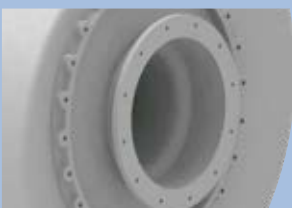

Flange connection
 P. 49



Shaft seal
 felt ring
 P. 50



Shaft seal
 Viton/Hastelloy
 P. 50



Protection grid
 P. 51

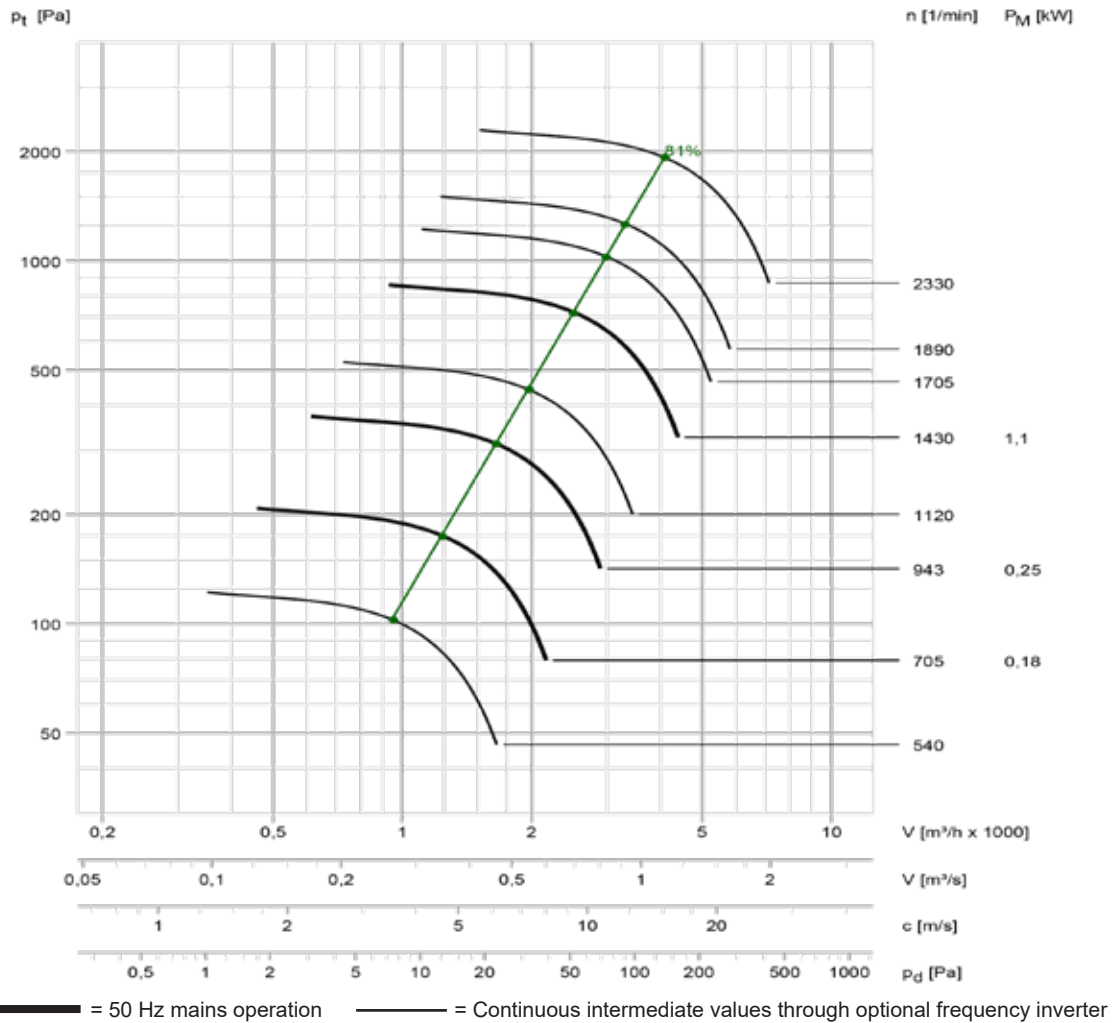

Acoustic level according to VDI 3731									
Speed [1/min]	Inlet level / outlet level of the duct sound level non-valuated; Lw3 = Lw4 [dB]								Lp2A (1 m) [dB(A)]
	63	125	250	500	1000	2000	4000	8000	
2330	98	96	104	90	84	77	69	59	79
1890	93	92	99	84	78	71	62	52	74
1705	89	97	84	79	73	65	56	46	67
1430	86	93	80	75	68	60	50	40	63
1120	80	88	73	68	61	52	42	31	57
943	77	84	69	63	56	47	36	25	52
705	78	64	59	52	44	35	24	11	40
540	72	57	52	44	36	26	14	1	33



Repair switch
P. 54



Motor cover
P. 51



Sound enclosure
P. 53



Fans optionally available for Ex-Zone!
P. 56

HF - Centrifugal fan
Type series HF R ...-17 D / R

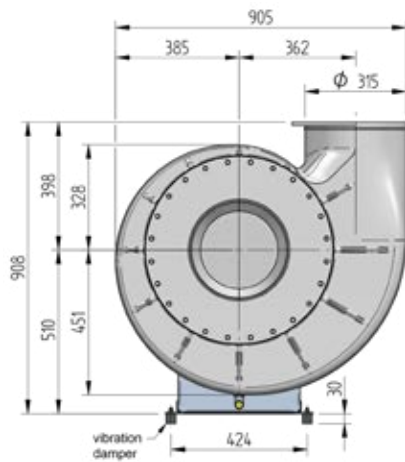

Direct drive

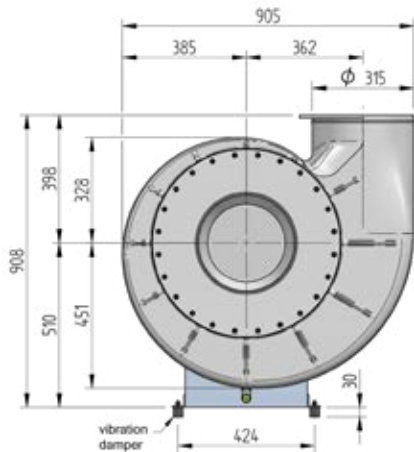
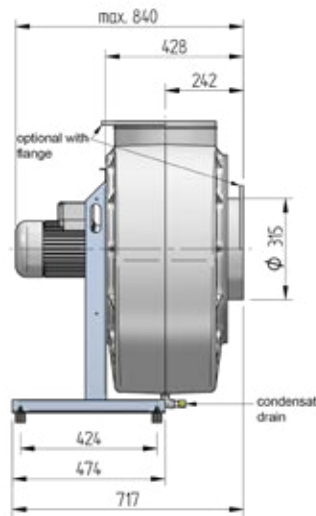

Belt drive (RF)

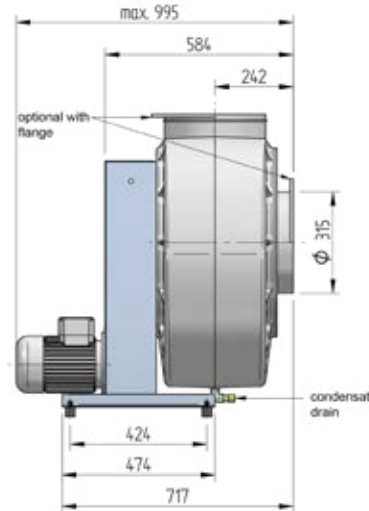

Accessories:

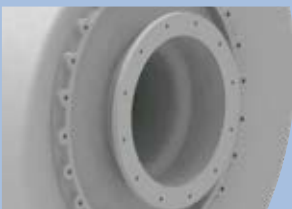

Flange connection
P. 49



Shaft seal
felt ring
P. 50



Shaft seal
Viton/Hastelloy
P. 50



Protection grid
P. 51

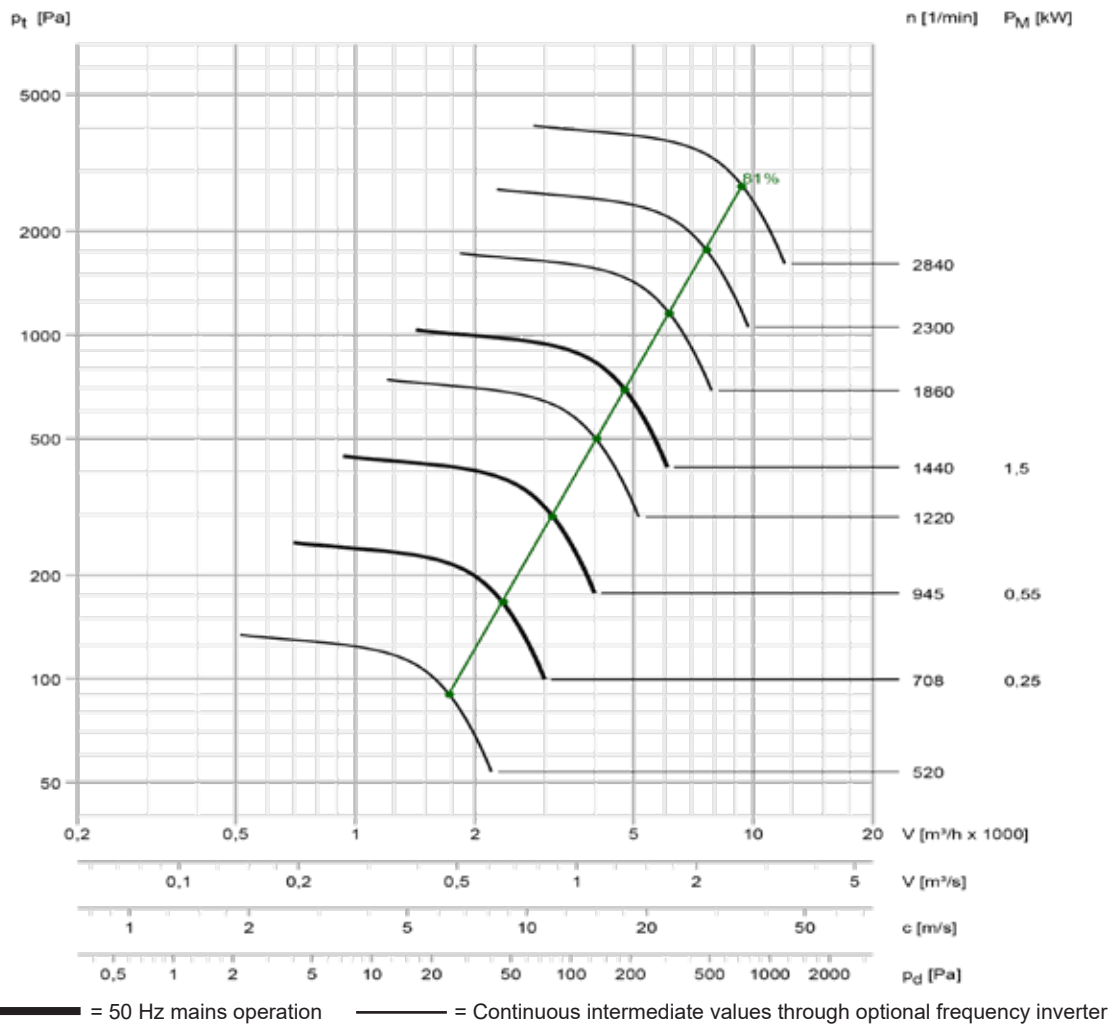

Acoustic level according to VDI 3731									
Speed [1/min]	Inlet level / outlet level of the duct sound level non-valuated; Lw3 = Lw4 [dB]								Lp2A (1 m) [dB(A)]
	63	125	250	500	1000	2000	4000	8000	
2840	99	99	97	105	92	88	83	77	85
2300	96	95	93	101	87	83	77	71	80
1860	90	89	97	85	81	76	71	64	73
1440	86	85	92	79	75	70	64	57	68
1220	83	81	89	76	71	66	60	53	64
945	77	85	72	68	64	58	51	44	55
708	71	79	66	62	57	51	44	36	49
520	66	73	59	55	49	43	36	28	42



Repair switch
P. 54



Motor cover
P. 51



Sound enclosure
P. 53



Fans optionally available
for Ex-Zone!
P. 56

HF - Centrifugal fan
Type series HF R ...-15 D / R

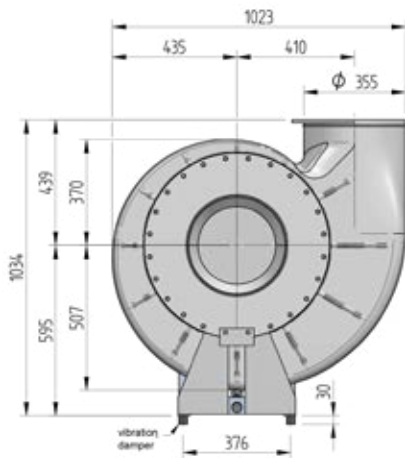

Direct drive

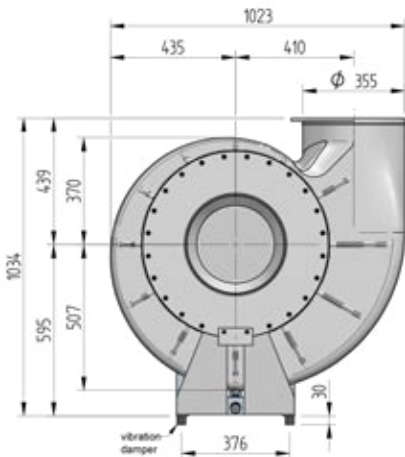
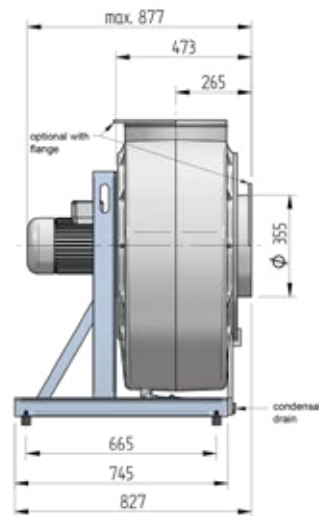

Belt drive (RF)

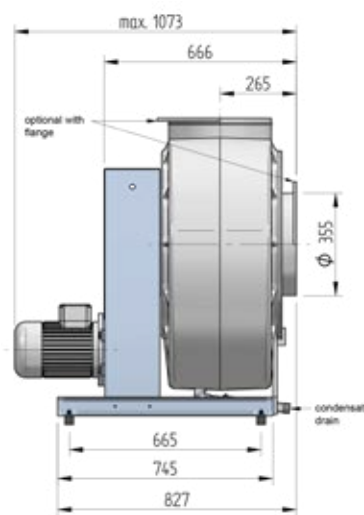

Accessories:

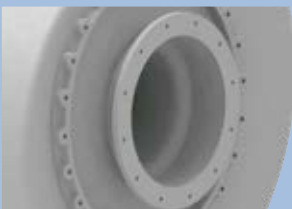

Flange connection
P. 49



Shaft seal
felt ring
P. 50



Shaft seal
Viton/Hastelloy
P. 50



Protection grid
P. 51

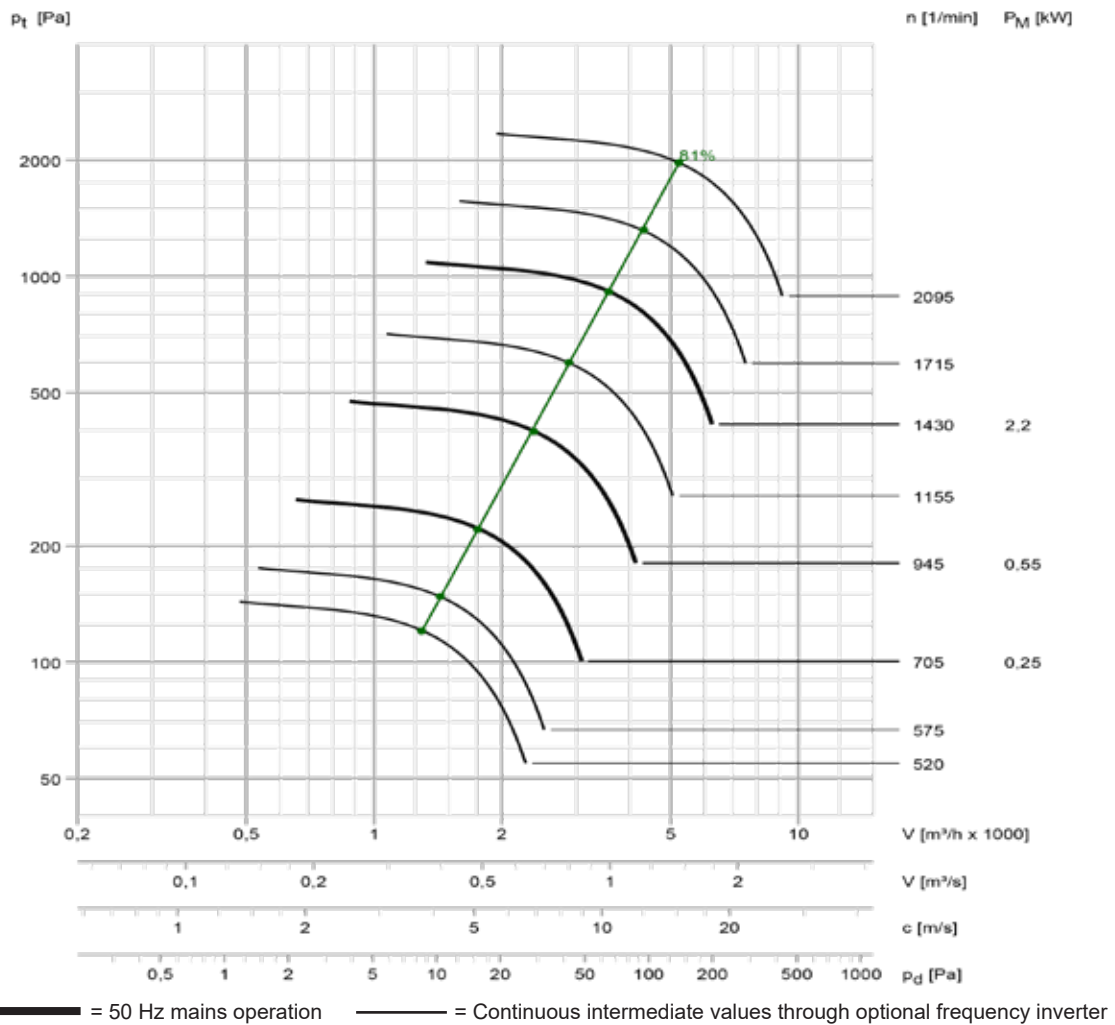

Acoustic level according to VDI 3731									
Speed [1/min]	Inlet level / outlet level of the duct sound level non-valuated; Lw3 = Lw4 [dB]								Lp2A (1 m) [dB(A)]
	63	125	250	500	1000	2000	4000	8000	
2095	99	98	105	91	85	78	69	59	80
1715	93	101	88	83	77	69	60	50	70
1430	89	97	83	78	72	64	54	43	66
1155	85	92	78	72	65	57	47	36	61
945	80	87	73	67	59	51	40	28	56
705	81	68	63	56	48	38	27	15	43
575	77	63	57	50	42	32	20	7	38
520	74	60	54	47	38	28	17	4	35



Repair switch
P. 54



Motor cover
P. 51



Sound enclosure
P. 53



Fans optionally available
for Ex-Zone!
P. 56

HF - Centrifugal fan
Type series HF R ...-17 D / R

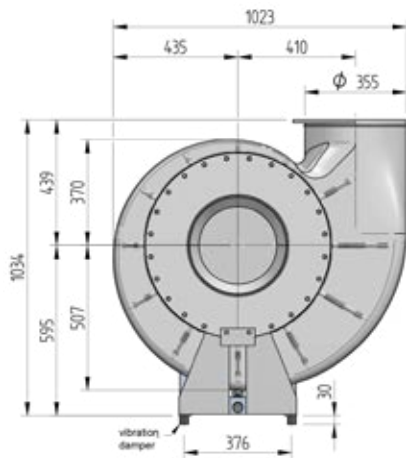

Direct drive

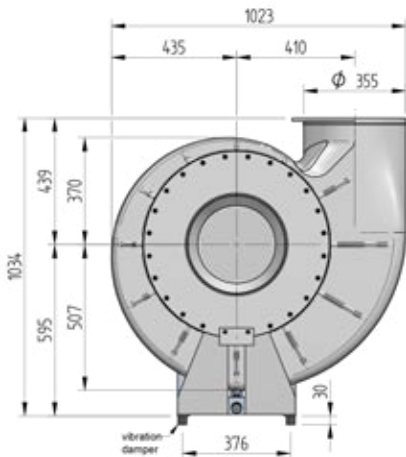
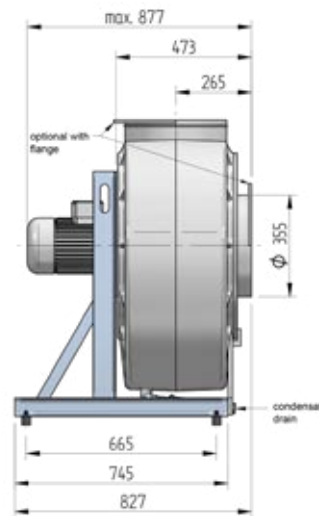

Belt drive (RF)

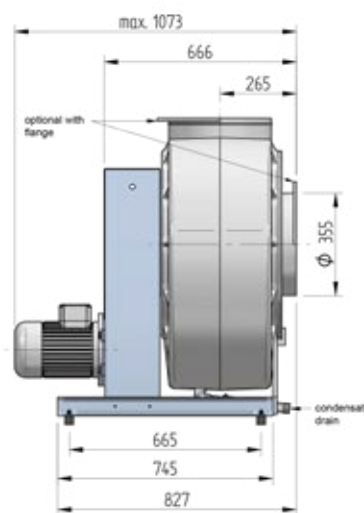

Accessories:

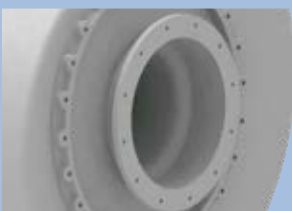

Flange connection
P. 49



Shaft seal
felt ring
P. 50



Shaft seal
Viton/Hastelloy
P. 50



Protection grid
P. 51

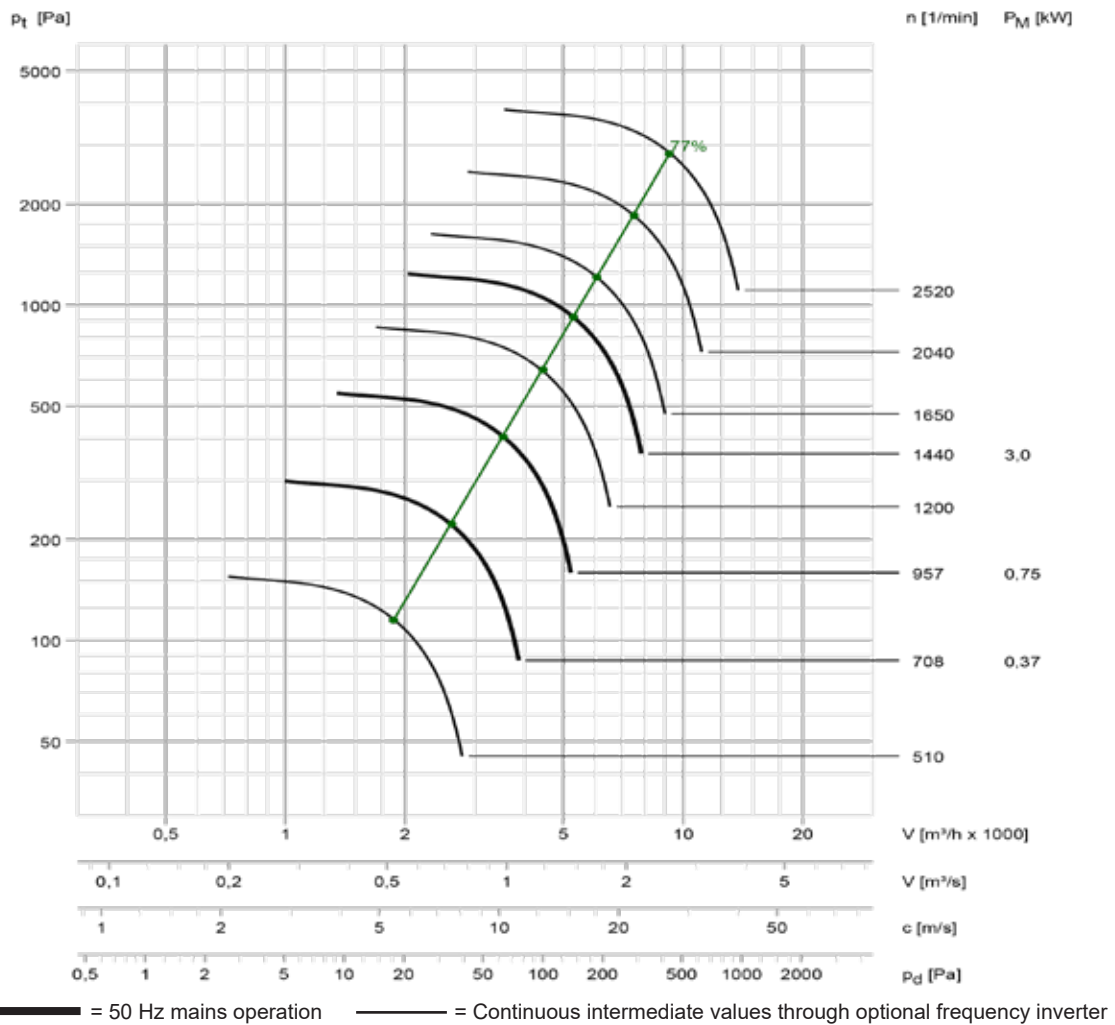

Acoustic level according to VDI 3731									
Speed [1/min]	Inlet level / outlet level of the duct sound level non-valuated; Lw3 = Lw4 [dB]								Lp2A (1 m) [dB(A)]
	63	125	250	500	1000	2000	4000	8000	
2520	101	100	98	106	92	88	83	77	85
2040	97	69	94	101	88	83	78	71	81
1650	92	91	98	85	81	77	71	64	74
1440	89	88	96	82	78	73	67	61	71
1200	86	85	92	79	74	69	63	56	67
957	80	88	76	72	67	62	55	48	58
708	75	82	69	65	60	54	47	40	52
510	69	76	62	58	52	46	39	30	45



Repair switch
P. 54



Motor cover
P. 51



Sound enclosure
P. 53



Fans optionally available
for Ex-Zone!
P. 56

HF - Centrifugal fan
 Type series HF R ...-15 D / R
 optional for ATEX zone 1
 in GR ... or GL ...

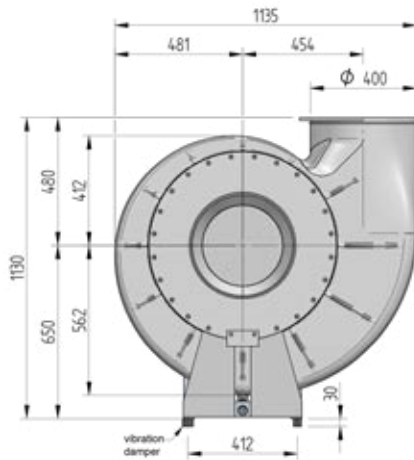

Direct drive

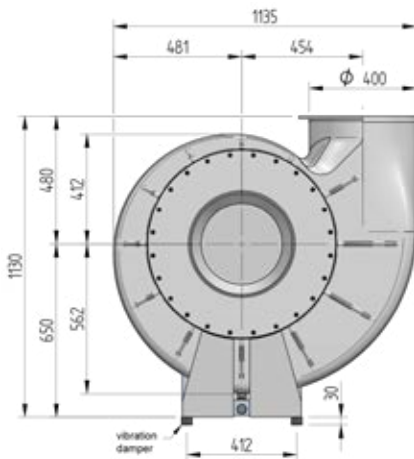
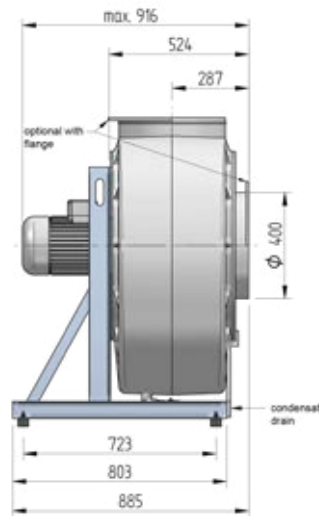

Belt drive (RF)

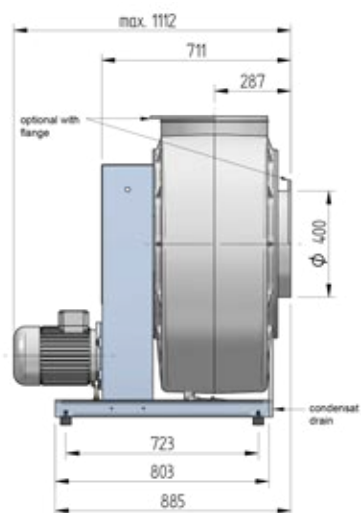

Accessories:

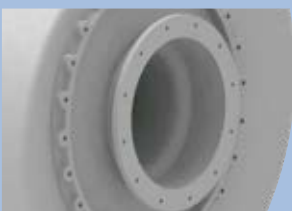

Flange connection
 P. 49



Shaft seal
 felt ring
 P. 50



Shaft seal
 Viton/Hastelloy
 P. 50



Protection grid
 P. 51

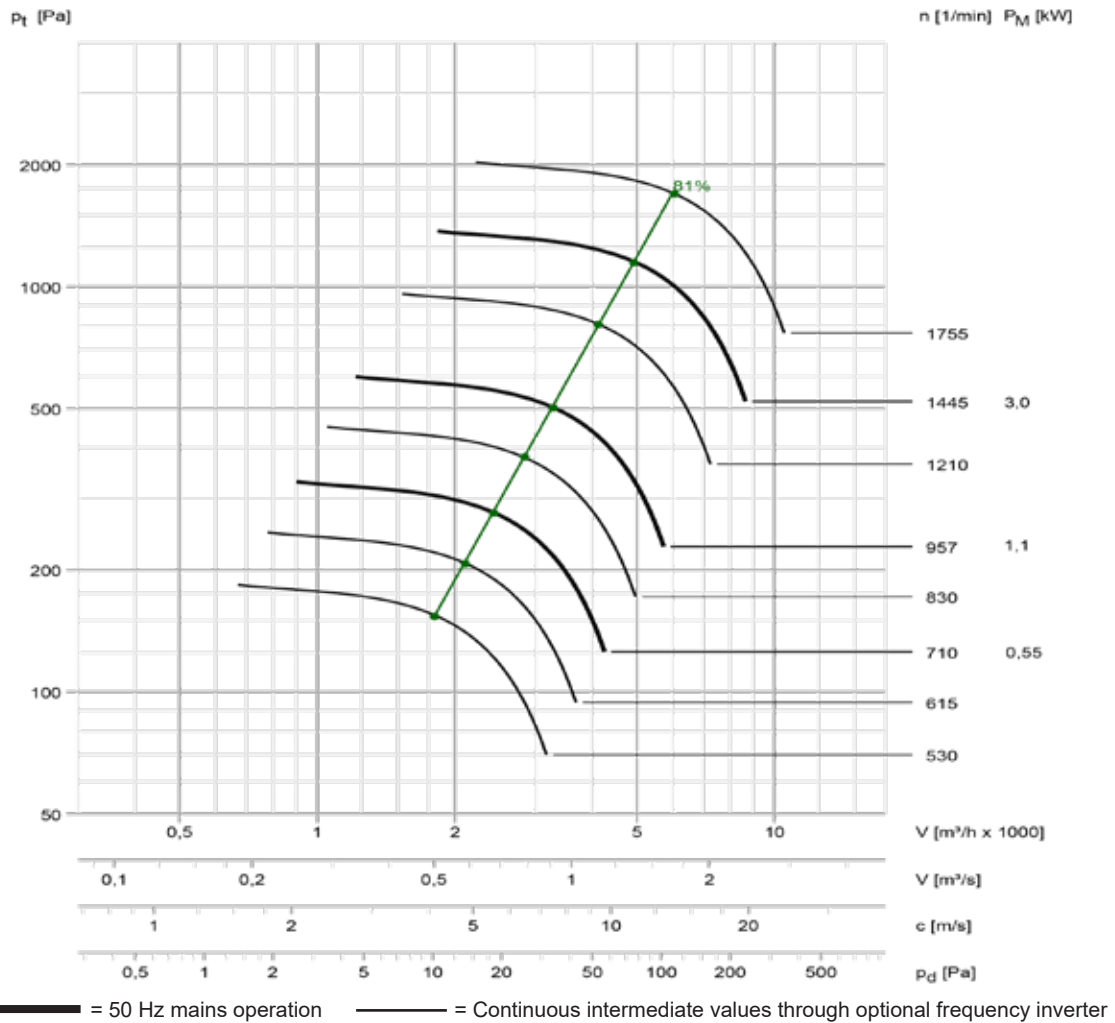

Acoustic level according to VDI 3731									
Speed [1/min]	Inlet level / outlet level of the duct sound level non-valuated; Lw3 = Lw4 [dB]								Lp2A (1 m) [dB(A)]
	63	125	250	500	1000	2000	4000	8000	
1755	97	105	92	87	81	73	64	54	74
1445	93	101	87	82	75	67	58	47	69
1210	89	96	82	77	70	62	52	41	65
957	84	91	77	71	63	54	44	32	59
830	88	75	70	64	56	47	37	24	50
710	85	71	66	59	51	42	31	19	46
615	82	68	62	55	47	37	26	13	42
530	78	64	58	51	42	32	21	8	39



Repair switch
P. 54



Motor cover
P. 51



Sound enclosure
P. 53



Fans optionally available for Ex-Zone!
P. 56

HF - Centrifugal fan
Type series HF R ...-15 D / R

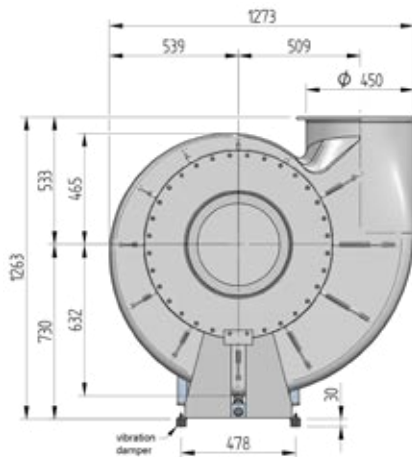

Direct drive

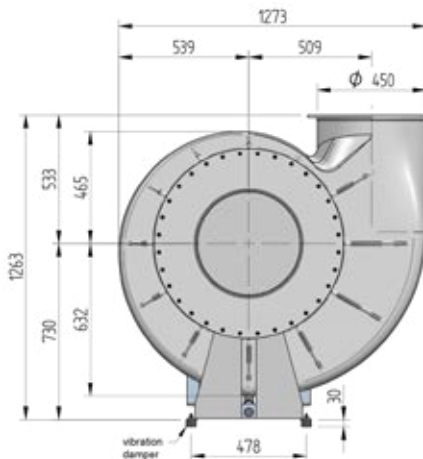
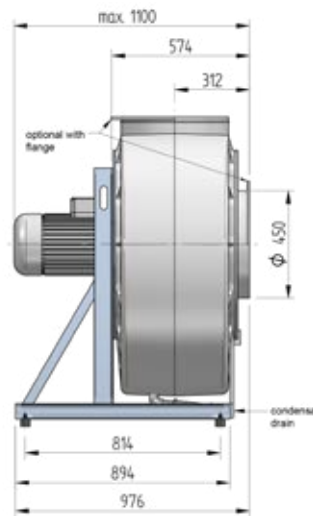

Belt drive (RF)

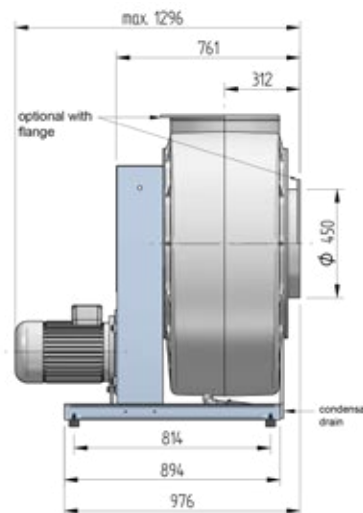

Accessories:

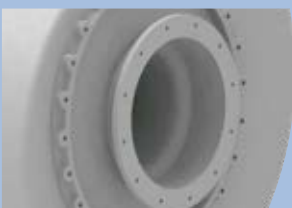

Flange connection
P. 49



Shaft seal
felt ring
P. 50



Shaft seal
Viton/Hastelloy
P. 50



Protection grid
P. 51

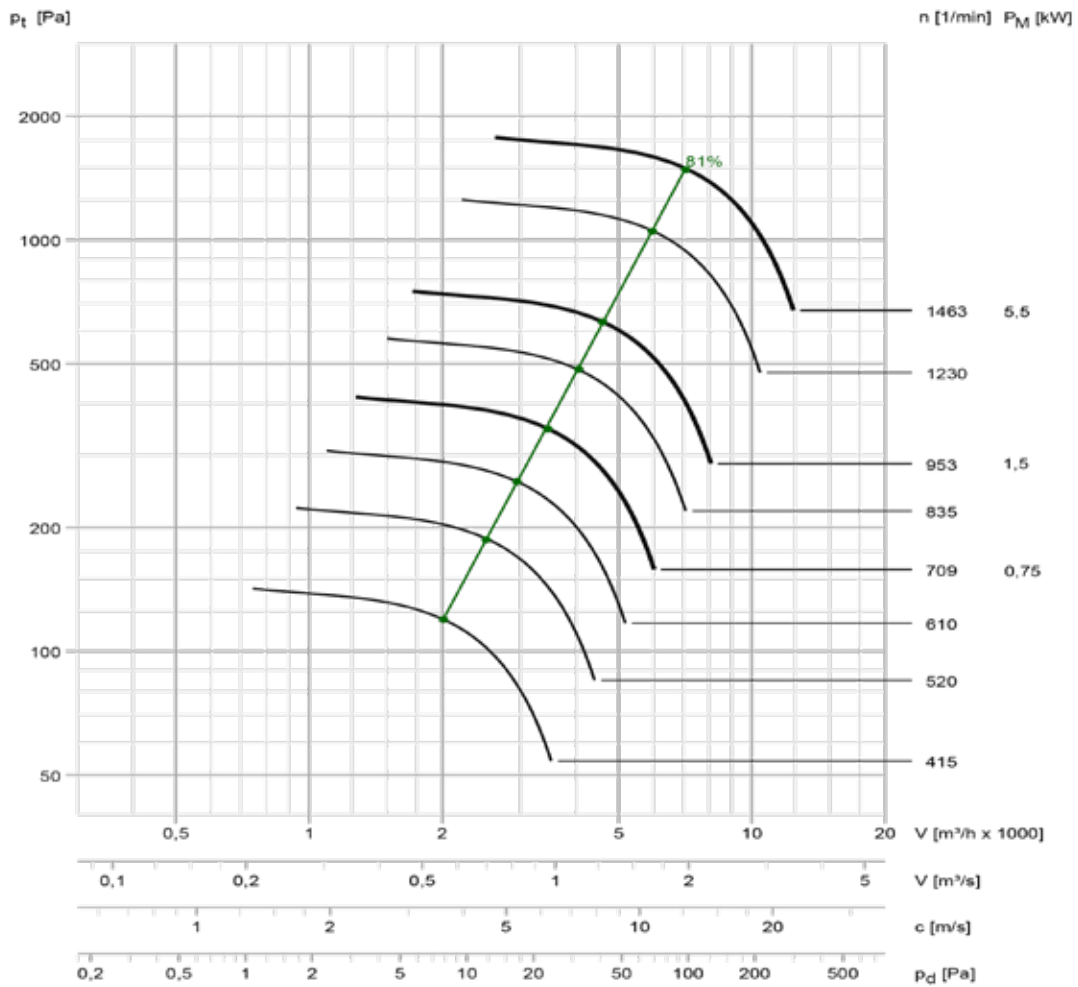

Acoustic level according to VDI 3731									
Speed [1/min]	Inlet level / outlet level of the duct sound level non-valuated; Lw3 = Lw4 [dB]								Lp2A (1 m) [dB(A)]
	63	125	250	500	1000	2000	4000	8000	
1463	97	105	91	86	79	71	62	51	73
1230	93	101	87	81	74	66	56	45	69
953	88	95	80	74	67	58	48	36	62
835	92	79	74	68	60	51	40	28	53
709	89	75	70	63	55	46	35	22	49
610	85	71	66	59	50	41	29	17	45
520	81	67	61	54	45	35	24	11	41
415	76	61	55	48	38	28	16	2	36



Repair switch
P. 54



Motor cover
P. 51



Sound enclosure
P. 53



Fans optionally available
for Ex-Zone!
P. 56

HF - Centrifugal fan
 Type series HF R ...-15 D / R
 optional for ATEX zone 1
 in GR ... or GL ...

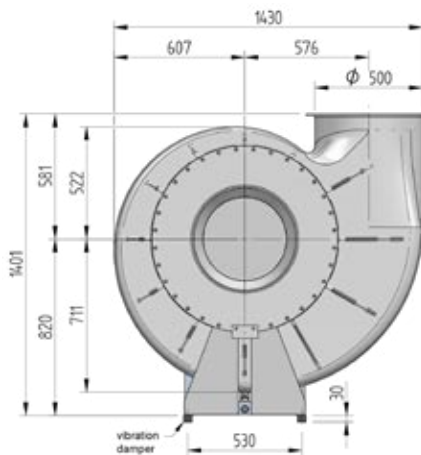

Direct drive

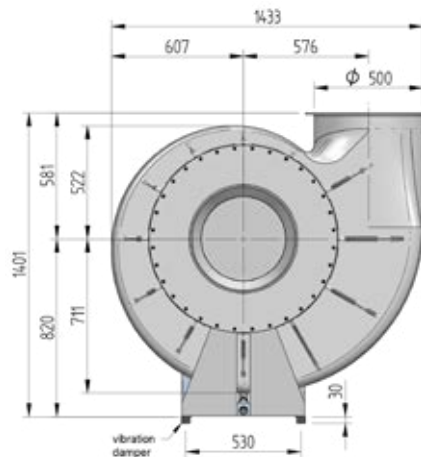
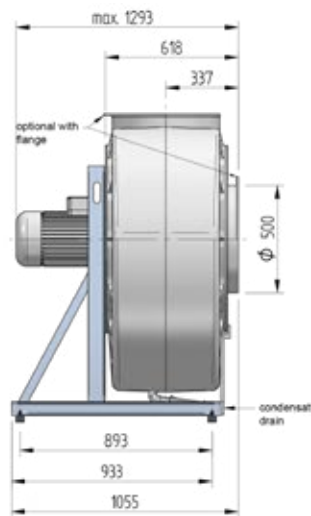

Belt drive (RF)

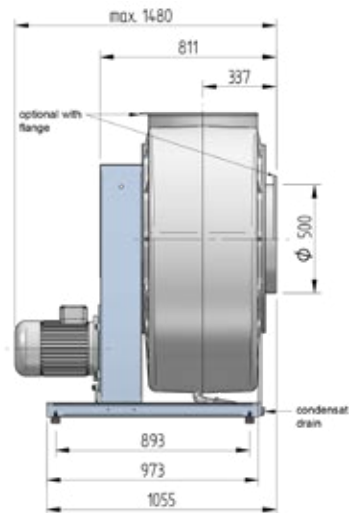

Accessories:

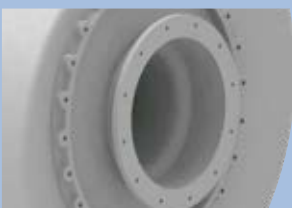

Flange connection
P. 49



Shaft seal
felt ring
P. 50



Shaft seal
Viton/Hastelloy
P. 50



Protection grid
P. 51

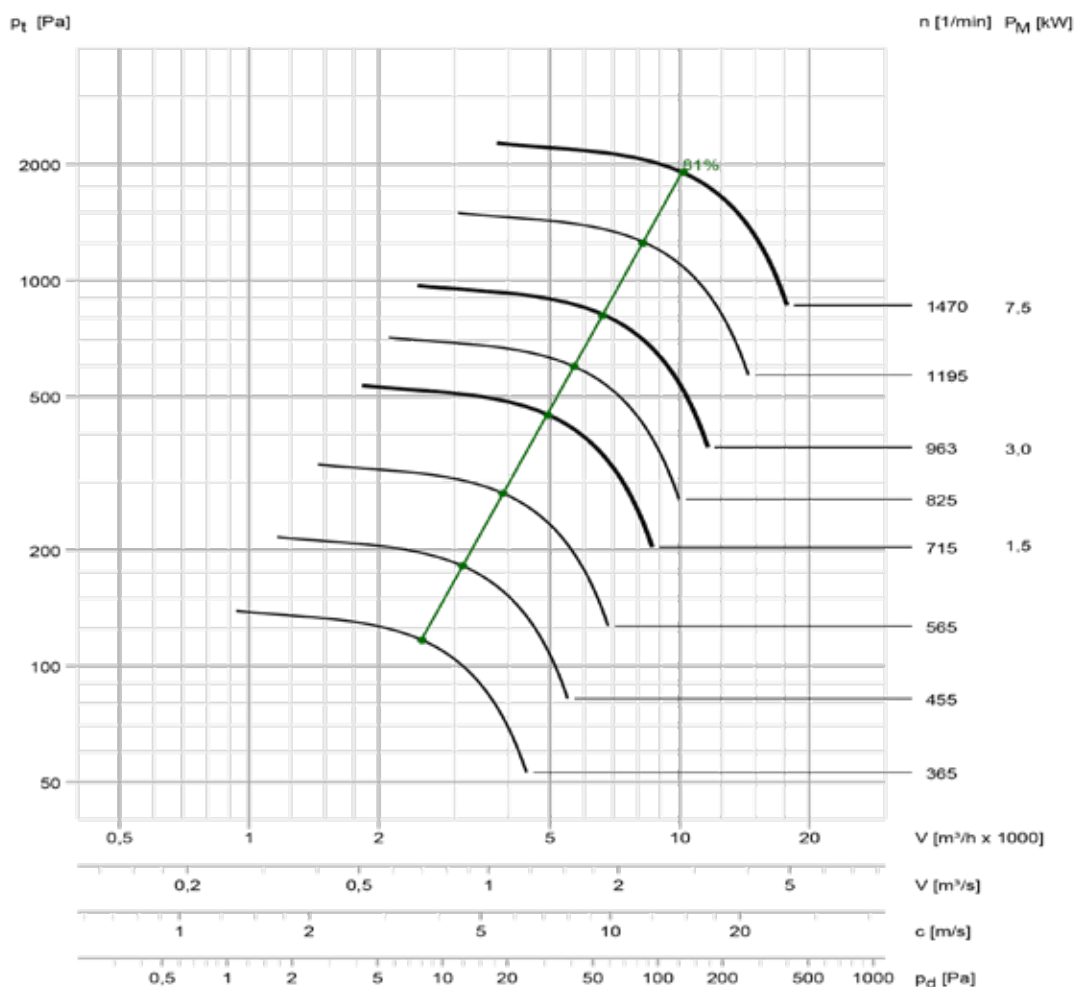

= 50 Hz mains operation
 = Continuous intermediate values through optional frequency inverter

Acoustic level according to VDI 3731									
Speed [1/min]	Inlet level / outlet level of the duct sound level non-valuated; Lw3 = Lw4 [dB]								Lp2A (1 m) [dB(A)]
	63	125	250	500	1000	2000	4000	8000	
1470	101	108	95	90	83	75	66	55	76
1195	96	104	90	84	77	69	59	48	71
963	92	99	84	78	71	62	52	40	66
825	96	82	78	71	64	54	44	32	56
715	92	79	74	67	59	50	39	26	53
565	87	73	67	60	52	42	30	17	47
455	82	68	61	54	45	35	23	9	41
365	77	62	55	47	38	27	15	1	36



Repair switch
P. 54



Motor cover
P. 51



Sound enclosure
P. 53



Fans optionally available
for Ex-Zone!
P. 56

Accessories for
HF - Centrifugal fans
Type series HF R ...-15 / 17 D



Vibration dampers

Protect against vibrations

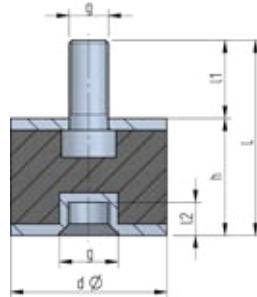

Ø	h	g	L	l1	l2
15	15	M4	28	13	8
20	15	M6	30	15	6
30	30	M8	50	20	8
40	30	M8	54	24	8
50	30	M10	64	34	8
70	45	M10	70	25	8

Sleeve with VA tightening straps

For easy flexible connection to duct



Size	Inlet side	Outlet side
Ø	Article no.	Article no.
125	441-063-100000	441-064-100000
140	441-063-100001	441-064-100001
160	441-063-100002	441-064-100002
180	441-063-100003	441-064-100003
200	441-063-100004	441-064-100004
250	441-063-100005	441-064-100005
280	441-063-100006	441-064-100006
315	441-063-100007	441-064-100007
355	441-063-100008	441-064-100008
400	441-063-100009	441-064-100009
450	441-063-100010	441-064-100010
500	441-063-100011	441-064-100011



Accessories for
HF - Centrifugal fans
Type series HF R ...-15 / 17 D

Flange connection

Recommended for higher demands on tightness and at higher pressures

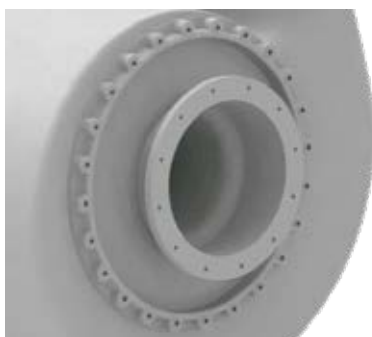

Size	Inlet side	Outlet side
Ø	Article no.	Article no.
125	441-060-125000	441-061-125000
140	441-060-140000	441-061-140000
160	441-060-160000	441-061-160000
180	441-060-180000	441-061-180000
200	441-060-200000	441-061-200000
250	441-060-250000	441-061-250000
280	441-060-280000	441-061-280000
315	441-060-315000	441-061-315000
355	441-060-355000	441-061-355000
400	441-060-400000	441-061-400000
450	441-060-450000	441-061-450000
500	441-060-500000	441-061-500000

Sleeve with flanges

For flexible connection with higher demands on tightness and at higher pressures



Size	Inlet side	Outlet side
Ø	Article no.	Article no.
125	441-063-000000	441-064-000000
140	441-063-000001	441-064-000001
160	441-063-000002	441-064-000002
180	441-063-000003	441-064-000003
200	441-063-000004	441-064-000004
250	441-063-000005	441-064-000005
280	441-063-000006	441-064-000006
315	441-063-000007	441-064-000007
355	441-063-000008	441-064-000008
400	441-060-400000	441-061-400000
450	441-063-000010	441-064-000010
500	441-063-000011	441-064-000011

Accessories for
HF - Centrifugal fans
Type series HF R ...-15 / 17 D



Shaft seal felt ring

Protects against leakage at the shaft passage



Size	Felt ring
Ø	Article no.
125 to 315	441-040-000000
355 to 500	441-040-000010

Shaft seal Viton/Hastelloy

Protects against leakage at the shaft passage



High-quality sealing system with lip seal made of fluororubber and shaft sleeve made of highly corrosion-resistant nickel-based alloy. Resistant to all inorganic acids, alkalis and hydrocarbons commonly used in chemical plant construction. Very suitable for humid medium.



Accessories for
HF - Centrifugal fans
Type series HF R ...-15 / 17 D

Protection grid

Protects against foreign bodies



Size	Inlet side	Outlet side
Ø	Article no.	Article no.
125	441-020-125000	441-021-125000
140	441-020-140000	441-021-140000
160	441-020-160000	441-021-160000
180	441-020-180000	441-021-180000
200	441-020-200000	441-021-200000
250	441-020-250000	441-021-250000
280	441-020-280000	441-021-280000
315	441-020-315000	441-021-315000
355	441-020-355000	441-021-355000
400	441-020-400000	441-021-400000
450	441-020-450000	441-021-450000
500	441-020-500000	441-021-500000

Motor cover

Protects the electric motor from weather influences



Size	Steel, galvanized	PVC
Ø	Article no.	Article no.
125	441-030-125000	441-030-125001
140	441-030-140000	441-030-140001
160	441-030-160000	441-030-160001
180	441-030-180000	441-030-180001
200	441-030-200000	441-030-200001
250	441-030-250000	441-030-250001
280	441-030-280000	441-030-280001
315	441-030-315000	441-030-315001
355		441-030-355001
400		441-030-400001
450		441-030-450001
500		441-030-500005

Accessories for
HF - Centrifugal fans
Type series HF R ...-15 / 17 D



Wall bracket set

For easy wall mounting

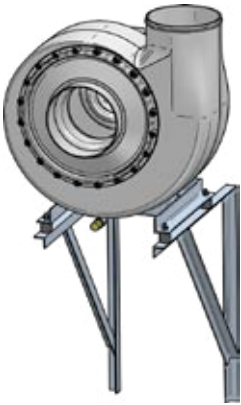

Size	Steel, galvanized
Ø	Article no.
125	017-829-102000
140	017-829-102000
160	017-829-104000
180	017-829-104000
200	017-829-106000
250	017-829-106000
280	017-829-108000
315	017-829-108000
355	017-829-110000
400	017-829-112000
450	017-829-112001
500	017-829-112001



Accessories for
HF - Centrifugal fans
Type series HF R ...-15 / 17 D

Sound enclosure GR 360° | Direct drive

Reduces the sound emission from the fan

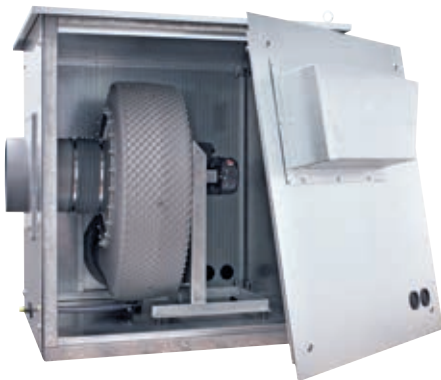

Size	Steel, galvanized	Plastic PP
Ø	Article no.	Article no.
125	440-820-000035	440-023-012500
140	440-820-000037	440-023-014000
160	440-820-000059	440-023-016001
180	440-820-000048	440-023-018000
200	440-820-000054	440-023-020000
250	440-820-000045	440-023-125000
280	440-820-000062	
315	440-820-000056	
355	440-820-000072	
400	440-820-000080	
450	440-820-000086	
500	440-820-000019	

Version in steel, galvanized:

- Frame construction with panels for easy access via turning bolt
- Suitable for outdoor installation
- Supply and exhaust air grille for self-ventilation with damped openings
- The scope of delivery includes bushings for air ducts, condensate drain, electro cables as well as lifting lugs and mounting profiles for steel construction or floor.
- Sound level reduction as standard approx. 14 dB at 250 Hz, versions for higher sound insulation requirements are available as an option

Version in plastic PP:

- Welded construction made of corrosion-resistant plastic twinwall panels access via door
- Suitable for outdoor installation
- Supply and exhaust air grille for self-ventilation with damped openings
- The scope of delivery includes bushings for air ducts, condensate drain, electro cables as well as lifting lugs and machine base.
- Sound level reduction approx. 10 dB at 250 Hz

Accessories for
HF - Centrifugal fans
Type series HF R ...-15 / 17 D
repair switch | Connecting
diagram



Connecting diagram for standard three-phase motor

Motor cable		Switch Y (400 V)				Switch Δ (230 V)			
Cable no.	Winding	Pin	Motor cable no.	Mains	Pin	Motor cable no.	Mains		
1	U1	L1	-	(L1)	L1	-	(L1)		
2	V1	L2	-	(L2)	L2	-	(L2)		
3	W1	L3	-	(L3)	L3	-	(L3)		
4	U2	T1	1 (U1)	-	T1	1 (U1) + 6 (W2)			
5	V2	T2	2 (V1)	-	T2	2 (V1) + 4 (U2)			
6	W2	T3	3 (W1)	-	T3	3 (W1) + 5 (V2)			
7	PTC	Y-jumper {							
8	PTC	4 (U2)							
		5 (V2)							
		6 (W2)							

Connection diagram for motors with two speeds | separate winding

Motor cable		Connections at repair switch					
Cable no.	Winding	Switch pins			Motor cable no.		
1	U1	on-site connection 380 V 3-phase	← L1	T1 →	1 (U1)	} low speed	
2	V1		← L2	T2 →	2 (V1)		
3	W1		← L3	T3 →	3 (W1)		
4	U2		← 2L1	2T1 →	4 (U2)	} high speed	
5	V2		← 2L2	2T2 →	5 (V2)		
6	W2		← 2L3	2T3 →	6 (W2)		
7	PTC						
8	PTC						

Connection diagram for motors with two speeds | Dahlander pole changing motor

Motor cable		Connections at repair switch					
Cable no.	Winding	Switch pins			Motor cable no.		
1	U1	on-site connection 380 V 3-phase	← L1	T1 →	1 (U1)	} low speed	
2	V1		← L2	T2 →	2 (V1)		
3	W1		← L3	T3 →	3 (W1)		
4	U2		← 2L1	2T1 →	4 (U2)	} high speed U1 - V1 - W1 must be star connected	
5	V2		← 2L2	2T2 →	5 (V2)		
6	W2		← 2L3	2T3 →	6 (W2)		
7	PTC						
8	PTC						



Accessories for
HF - Centrifugal fans
Type series HF R ...-15 / 17 D
repair switch | Connecting
diagram

Connection diagram for EC motors with alternating current / single-phase motors

Motor cable	
black	phase
blue	neutral
yellow-green	equipotential bonding

Connections at repair switch					
Switch pins					Motorlabel
on-site connection 230 V single-phase	←	L1	T1	→	black
	←	L2	T2	→	blue (neutral)

1. Connection only by trained and qualified electrician.
2. Before installation, check motor and motor connecting cable for damage.
Replace defective cables by new cables, **don't repair them.**
3. Check, if the end crimps are firmly seated and replace them, if necessary.
4. Tighten the cable glands firmly, withdrawal of the cable must not be possible.
5. Connect the conductors to the repair switch according to the pin allocation table, **note the information given on the motor type label.**
6. The conductors must be put on correctly without squeezing or distortion in the repair switch.
7. The maximum cable length between potentiometer and EC motor is approximately 15 m.
8. Potential free status signaling contacts in the repair switch for on-site wiring on Wago connectors.

ATEX 2014/34/EU



HLU fans according to ATEX 2014/34/EU

The ATEX Directive 2014/34/EU regulates the requirements with regard to placing products on the market that are used in potentially explosive atmospheres. The term ATEX is derived from the French abbreviation “Atmosphère explosible” and is used as a synonym for the two directives of the

European Community in the area of explosion protection, ATEX Directive 2014/34/EU and ATEX Directive 1999/92/EG. The design of fans in the ATEX area is described in detail in the norms DIN EN 14986 and DIN EN ISO 80079.

Explosion protection is differentiated according the conveyed atmosphere (inside) and the surroundings of the installation site (outside).

HLU supplies fans for the ATEX Zones 2 and 1 for different zone combinations.

inside	outside
Zone 1	Zone 1
Zone 1	Zone 2
Zone 2	Zone 2
Zone 2	no Zone

HF -centrifugal fan in ATEX version – for Zone 2 inside / no Zone outside:



HF -centrifugal fan in ATEX version – for Zone 2 inside / Zone 2 outside:

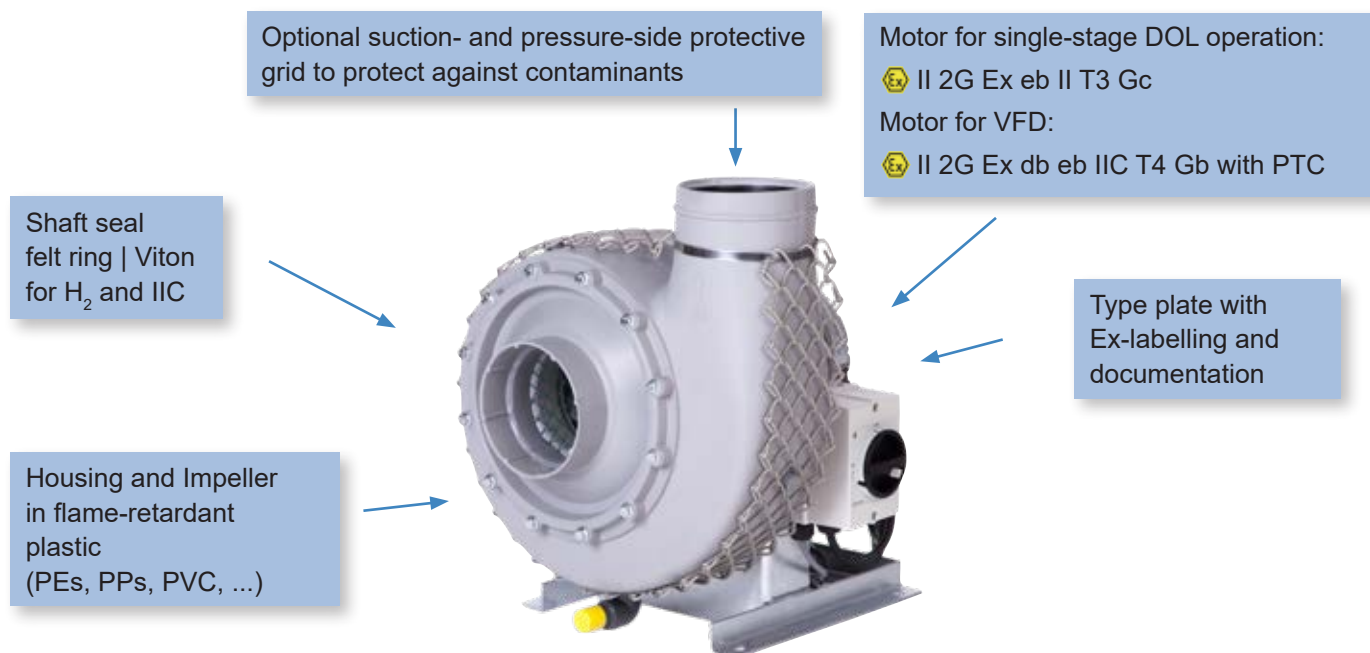

HF -centrifugal fan in ATEX version – for Zone 1 inside / Zone 2 outside: – for Zone 1 inside / Zone 1 outside:

HLU fans for ATEX Zone 1 are made of electrical conductive plastics (el).

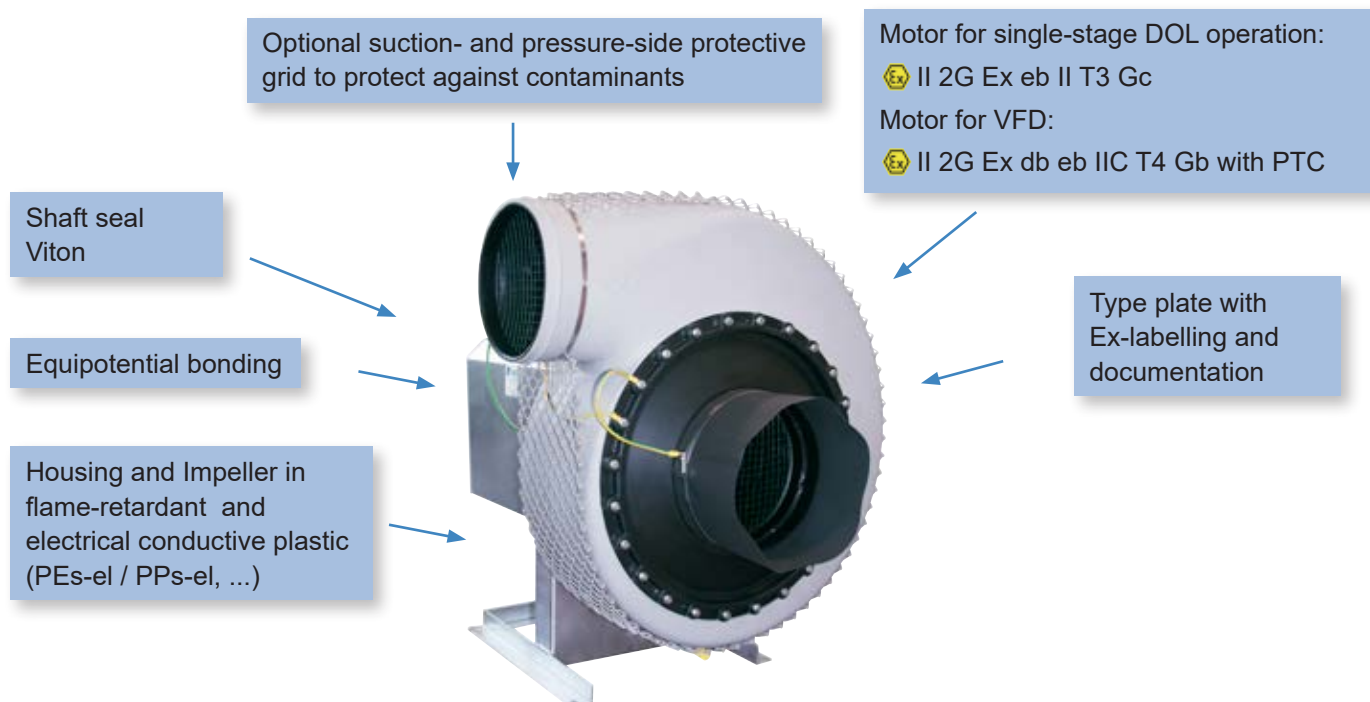

ATEX 2014/34/EU



You will see on the fan's type plate a permanent identification of the explosion protection. The following illustration explains the labelling of equipment for potentially explosive atmospheres:

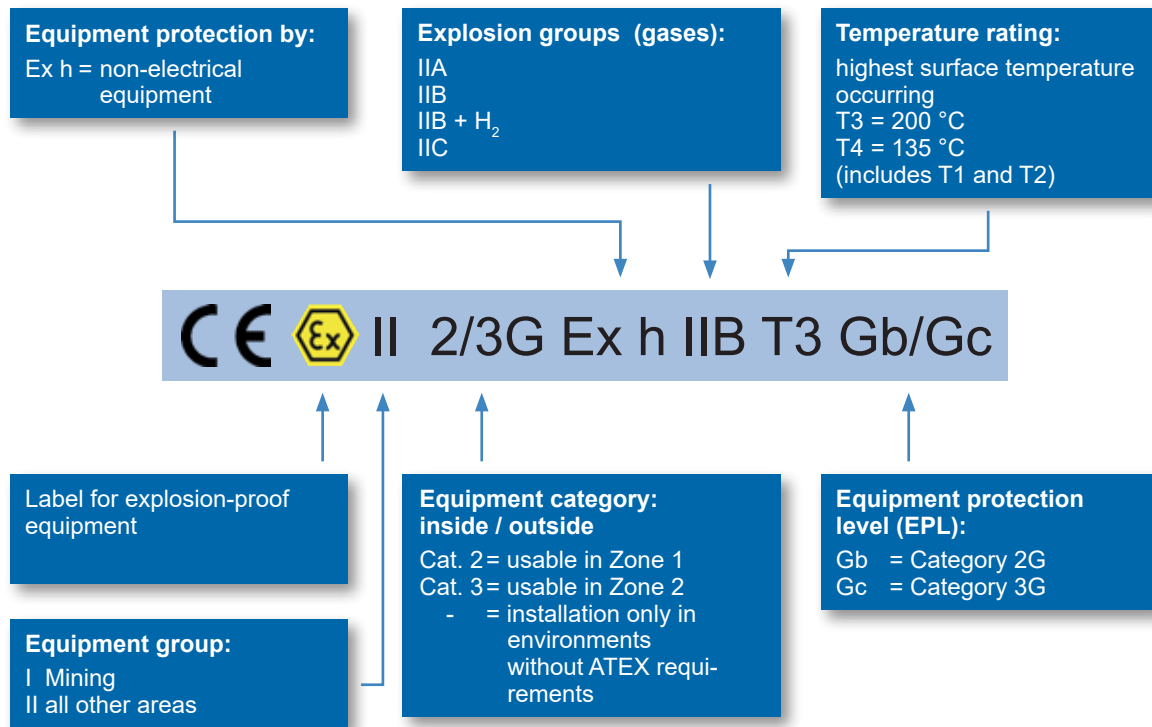

The operator of a facility is obligated to conduct a risk assessment. For questions regarding the Zone classification, you can contact various test centres such as for example safety engineers and special consultants. The following tables serve as reference:

An explosive gas atmosphere exists ...	ATEX Ex Zone	ATEX Device category	IEC EPL	(International) (Equipment Protection Level)
for more than 30 min. per year, however, less than 50% of the operational period daily	Zone 1	Category 2G		Gb
for a max. of 30 min. in a year	Zone 2	Category 3G		Gc

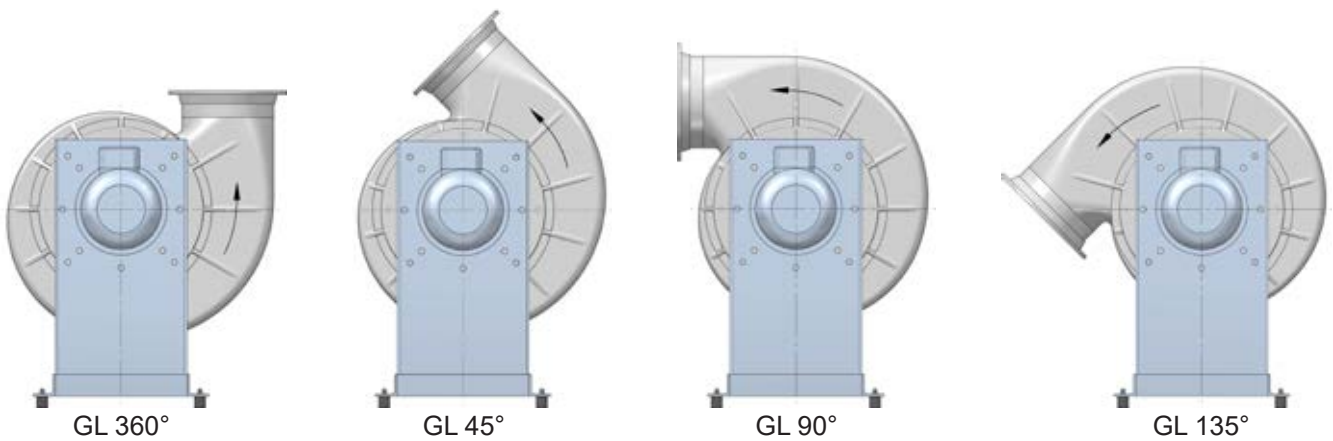
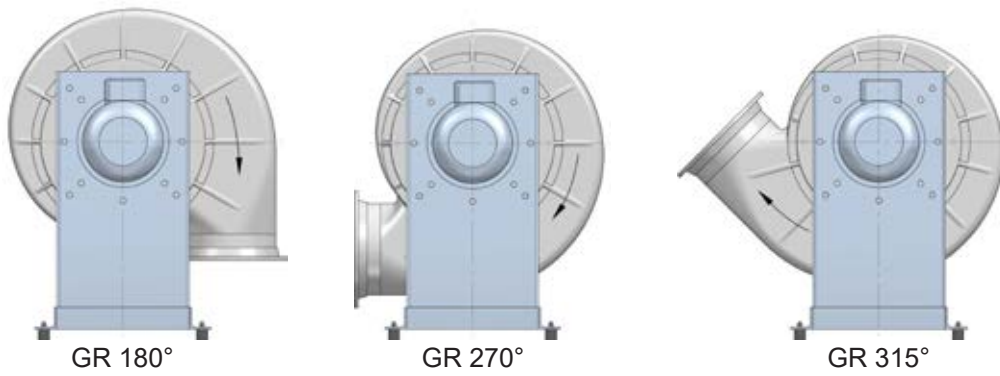
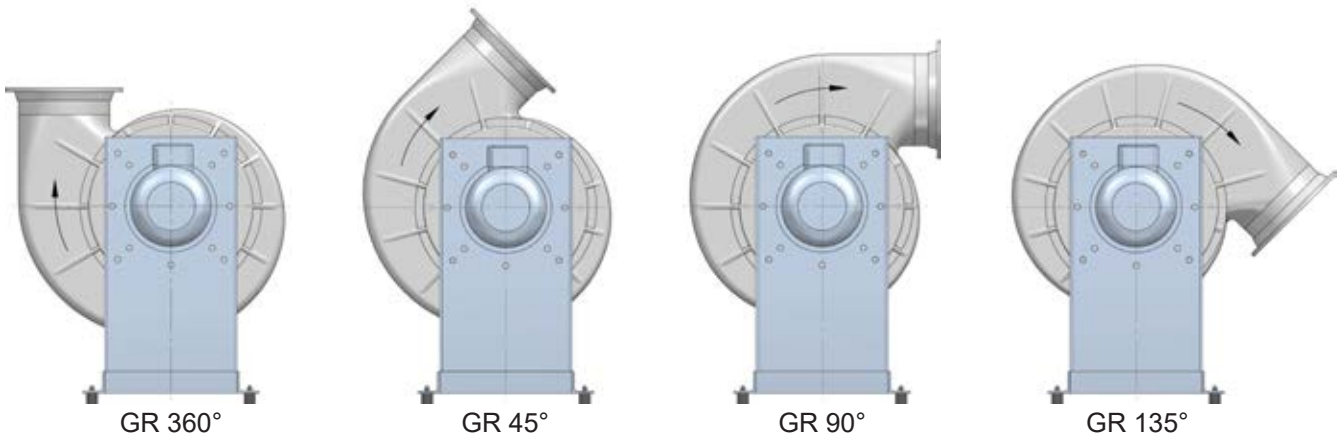

www.plasticagroup.co.uk

Plastica Technologies Ltd

Unit 2 Shaw Park Business Village,
Shaw Road, Wolverhampton,
WV10 9LE

Tel. +44(0)-1564-43211

info@plastica.tech